



SV670N-INT Series Servo Drive Selection Guide



Industrial
Automation



Intelligent
Elevator



New Energy
Vehicle



Industrial
Robot



Rail
Transit



Data code PS00009734A00

Preface

Introduction

Thank you for purchasing the SV670N-INT series servo drive.

The SV670N-INT series servo drive is a high-end servo drive designed based on global-leading standards and high-end application needs. It is featured with high speed, high precision, high performance, and tuning-free function. Compliant with CE, UL, KC, EAC, UKCA certification requirements and top international quality standards, it is specially suitable for high-end applications,

The drive covers a power range from 0.05 kW to 7.5 kW and carries EtherCAT communication interfaces to work with the host controller for a networked operation of multiple servo drives. The drive comes with the ITune function which supports adaptive stiffness level setting, inertia auto-tuning, and vibration suppression for easy use. The servo drive, together with an MS1 series high-response servo motor (with ultra-low, low or medium inertia) equipped with a 23-bit single-turn/multi-turn absolute encoder or a third-party servo motor, serves to deliver a quiet and stable operation and accurate process control through the fully closed-loop function and internal process segment function.

In addition, the drive provides a 18-month warranty and supports STO function as an optional function. It is equipped with dynamic braking function as standard. The SV670N-INT series servo drive aims to achieve quick and accurate position control, speed control, and torque control through high-performance solutions for automation equipment in such industries as electronic manufacturing, lithium batteries, manipulators, packaging, and machine tools.

This manual provides instructions on product selection, including the list of supporting components, technical data on the drive and motor, and the selection guide of cables.

More documents

Name	Data Code	Description
SV670N-INT Series Servo Drive Selection Guide	PS00009734	Presents instructions on product selection, including the list of supporting components, technical data on the drive and motor, and the selection guide of cables.
SV670N-INT Series Servo Drive Installation Guide	PS00009738	Presents installation of the servo drive, including installation steps, mechanical installation, and electrical installation.
SV670N-INT Series Servo Drive Hardware Guide	PS00009735	Presents electrical design guidance of the equipment, description of terminals, required certificates and standards and solutions to common EMC problems.
SV670N-INT Series Servo Drive Commissioning Guide	PS00009757	Presents the parameters, troubleshooting, operating panel, commissioning software, and commissioning flow and steps.
SV670N-INT Series Servo Drive Function Guide	PS00009756	Presents functions and parameters, including function overview, basic servo functions, adjustment and parameter list.
SV670N-INT Series Servo Drive Communication Guide	PS00009755	Presents functions and parameters of the servo drive, including EtherCAT communication configuration, parameter description, and communication application cases.
SV670N-INT Series Servo Drive Troubleshooting Guide	PS00009737	Presents faults and fault levels, the troubleshooting process, warning codes and fault codes.

Name	Data Code	Description
SV670N-INT Series Servo Drive Maintenance Guide	PS00009754	Presents instructions on maintenance and repair of the equipment.
SV670N-INT Series Servo Drive Manual Package	PS00009736	Presents information on selection, installation, commissioning, function, troubleshooting and parameters of the equipment.

Revision History

Date	Version	Description
August 2023	A00	First release

Access to the Guide

This guide is not delivered with the product. You can obtain the PDF version in the following way:

- Do keyword search at <http://www.inovance.com>.
- Scan the QR code on the equipment to acquire more.
- Scan the QR code below to install the app, where you can search for and download manuals.



Warranty

Inovance provides warranty service within the warranty period (as specified in your order) for any fault or damage that is not caused by improper operation of the user. You will be charged for any repair work after the warranty period expires.

Within the warranty period, maintenance fee will be charged for the following damage:

- Damage caused by operations not following the instructions in the user guide
- Damage caused by fire, flood, or abnormal voltage
- Damage caused by unintended use of the product
- Damage caused by use beyond the specified scope of application of the product
- Damage or secondary damage caused by force majeure (natural disaster, earthquake, and lightning strike)

The maintenance fee is charged according to the latest Price List of Inovance. If otherwise agreed upon, the terms and conditions in the agreement shall prevail.

For details, see the Product Warranty Card.

Table of Contents

Preface.....	1
1 Model Selection.....	6
1.1 Model Selection List.....	6
2 SV670N-INT Series Servo Drives	9
2.1 Product Information	9
2.1.1 Components	10
2.1.2 Product Dimensions.....	12
2.2 Product Specifications.....	12
2.2.1 Electrical Specifications	12
2.2.2 Technical Data	15
2.2.3 Technical Data of EtherCAT Communication	18
2.2.4 Dynamic Brake Characteristics	18
2.2.5 Load Moment of Inertia	19
3 MS1-R Series Motors	20
3.1 Product Information	20
3.1.1 Model and Nameplate.....	20
3.1.2 Components	21
3.1.3 Motor Model.....	22
3.2 Product Specifications.....	22
3.2.1 Mechanical Characteristics	22
3.2.2 Overload Characteristics	24
3.2.3 Derating Characteristics	26
3.2.4 Temperature Curve of the Oil Seal.....	27
3.2.5 Load Moment of Inertia	27
3.3 Selection Instructions.....	27
3.4 Motors with Low Inertia and Small Capacity (MS1H1)	29
3.4.1 MS1H1-05B30CB-A33*Z-INT	29
3.4.2 MS1H1-10B30CB-A33*Z-INT	30
3.4.3 MS1H1-20B30CB-A33*R-INT	31
3.4.4 MS1H1-40B30CB-A33*R-INT	32
3.4.5 MS1H1-55B30CB-A33*R-INT	33
3.4.6 MS1H1-75B30CB-A33*R-INT	34
3.4.7 MS1H1-10C30CB-A33*R-INT	35
3.5 Motors with Low Inertia and Medium Capacity (MS1H2)	36

3.5.1 MS1H2-10C30CB-A33*R-INT	36
3.5.2 MS1H2-10C30CD-A33*R-INT	37
3.5.3 MS1H2-15C30CB-A33*R-INT	38
3.5.4 MS1H2-15C30CD-A33*R-INT	39
3.5.5 MS1H2-20C30CB-A33*R-INT	40
3.5.6 MS1H2-20C30CD-A33*R-INT	41
3.5.7 MS1H2-25C30CB-A33*R-INT	42
3.5.8 MS1H2-25C30CD-A33*R-INT	43
3.5.9 MS1H2-30C30CB-A33*R-INT	44
3.5.10 MS1H2-30C30CD-A33*R-INT	45
3.5.11 MS1H2-40C30CB-A33*R-INT	46
3.5.12 MS1H2-40C30CD-A33*R-INT	47
3.5.13 MS1H2-50C30CB-A33*R-INT	48
3.5.14 MS1H2-50C30CD-A33*R-INT	49
3.6 Motors with Medium Inertia and Medium Capacity (MS1H3)	50
3.6.1 MS1H3-85B15CB-A33*R-INT	50
3.6.2 MS1H3-85B15CD-A33*R-INT	51
3.6.3 MS1H3-13C15CB-A33*R-INT	52
3.6.4 MS1H3-13C15CD-A33*R-INT	53
3.6.5 MS1H3-18C15CB-A33*R-INT	54
3.6.6 MS1H3-18C15CD-A33*R-INT	55
3.6.7 MS1H3-29C15CB-A33*R-INT	56
3.6.8 MS1H3-29C15CD-A33*R-INT	57
3.6.9 MS1H3-44C15CB-A33*R-INT	58
3.6.10 MS1H3-44C15CD-A33*R-INT	59
3.6.11 MS1H3-55C15CD-A33*R-INT	60
3.6.12 MS1H3-75C15CD-A33*R-INT	61
3.7 Motors with Medium Inertia and Small Capacity (MS1H4)	62
3.7.1 MS1H4-10B30CB-A33*Z-INT	62
3.7.2 MS1H4-20B30CB-A33*R-INT	63
3.7.3 MS1H4-40B30CB-A33*R-INT	64
3.7.4 MS1H4-55B30CB-A33*R-INT	65
3.7.5 MS1H4-75B30CB-A33*R-INT	66
3.7.6 MS1H4-10C30CB-A33*R-INT	67
4 Options	68
4.1 Option List	68
4.2 Applicable Cables	68
4.2.1 Model Number of Cables	68

4.2.2 Cable Type	69
4.2.3 Cable Selection.....	71
4.2.4 Cable Connectors	76
4.3 Peripheral Electrical Components.....	78
4.3.1 Fuse.....	78
4.3.2 Electromagnetic Contactor.....	79
4.3.3 Circuit Breaker	80
4.3.4 AC Input Reactor	81
4.3.5 EMC Filter	83
4.3.6 Magnetic Ring and Magnetic Buckle.....	85
4.4 Shield bracket	86
4.5 Absolute Encoder Batteries	87
5 Certification Requirements.....	88
6 Service and Support	89

1 Model Selection

1.1 Model Selection List

Servo motor				Servo drive SV670-INT series			
Models without brake	Models with brake	Flange size (mm)	Capacity (kW)	Voltage class	Size	Model	No.
MS1H1 ($n_N=3000\text{rpm}$, $n_{\max}=7000\text{rpm}$)							
MS1H1-05B30CB-A330Z-INT	MS1H1-05B30CB-A332Z-INT	40	0.05	Single-phase/ Three-phase 200 V	A	S1R6	00002
MS1H1-10B30CB-A330Z-INT	MS1H1-10B30CB-A332Z-INT	40	0.1	Single-phase/ Three-phase 200 V			
MS1H1-20B30CB-A331R-INT	MS1H1-20B30CB-A334R-INT	60	0.2	Single-phase/ Three-phase 200 V			
MS1H1-40B30CB-A331R-INT	MS1H1-40B30CB-A334R-INT	60	0.4	Single-phase/ Three-phase 200 V		S2R8	00003
MS1H1-55B30CB-A331R-INT	-	80	0.55	Single-phase/ Three-phase 200 V	C	S5R5	00005
MS1H1-75B30CB-A331R-INT	MS1H1-75B30CB-A334R-INT	80	0.75	Single-phase/ Three-phase 200 V		S5R5	00005
MS1H1-10C30CB-A331R-INT	MS1H1-10C30CB-A334R-INT	80	1.0	Single-phase/ Three-phase 200 V	C	S7R6	00006
MS1H2 ($n_N=3000\text{rpm}$, $n_{\max}=6000\text{rpm}$)							
MS1H2-10C30CB-A331R-INT	MS1H2-10C30CB-A334R-INT	100	1.0	Single-phase/ Three-phase 200 V	C	S7R6	00006
MS1H2-10C30CD-A331R-INT	MS1H2-10C30CD-A334R-INT	100	1.0	Three-phase 400 V		T3R5	10001
MS1H2-15C30CB-A331R-INT	MS1H2-15C30CB-A334R-INT	100	1.5	Single-phase/ Three-phase 200 V	D	S012	00007
MS1H2-15C30CD-A331R-INT	MS1H2-15C30CD-A334R-INT	100	1.5	Three-phase 400 V	C	T5R4	10002

Servo motor				Servo drive SV670-INT series			
Models without brake	Models with brake	Flange size (mm)	Capacity (kW)	Voltage class	Size	Model	No.
MS1H2-20C30CB-A331R-INT	MS1H2-20C30CB-A334R-INT	100	2.0	Single-phase/ Three-phase 200 V	D	S012	00007
				Three-phase 200 V	E	S018	00008
MS1H2-20C30CD-A331R-INT	MS1H2-20C30CD-A334R-INT	100	2.0	Three-phase 400 V	D	T8R4	10003
MS1H2-25C30CB-A331R-INT	MS1H2-25C30CB-A334R-INT	100	2.5	Three-phase 200 V	E	S022	00009
MS1H2-25C30CD-A331R-INT	MS1H2-25C30CD-A334R-INT	100	2.5	Three-phase 400 V	D	T8R4	10003
MS1H2-30C30CB-A331R-INT	MS1H2-30C30CB-A334R-INT	130	3.0	Three-phase 200 V	E	S022	00009
MS1H2-30C30CD-A331R-INT	MS1H2-30C30CD-A334R-INT	130	3.0	Three-phase 400 V	D	T012	10004
MS1H2-40C30CB-A331R-INT	MS1H2-40C30CB-A334R-INT	130	4.0	Three-phase 200 V	E	S027	00010
MS1H2-40C30CD-A331R-INT	MS1H2-40C30CD-A334R-INT	130	4.0	Three-phase 400 V		T017	10005
MS1H2-50C30CB-A331R-INT	MS1H2-50C30CB-A334R-INT	130	5.0	Three-phase 200 V		S027	00010
MS1H2-50C30CD-A331R-INT	MS1H2-50C30CD-A334R-INT	130	5.0	Three-phase 400 V		T021	10006
MS1H3 ($n_N=1500\text{rpm}$, $n_{\max}=4500\text{rpm}$)							
MS1H3-85B15CB-A331R-INT	MS1H3-85B15CB-A334R-INT	130	0.85	Single-phase/ Three-phase 200 V	C	S7R6	00006
MS1H3-85B15CD-A331R-INT	MS1H3-85B15CD-A334R-INT	130	0.85	Three-phase 400 V		T3R5	10001
MS1H3-13C15CB-A331R-INT	MS1H3-13C15CB-A334R-INT	130	1.3	Single-phase/ Three-phase 200 V	D	S012	00007
MS1H3-13C15CD-A331R-INT	MS1H3-13C15CD-A334R-INT	130	1.3	Three-phase 400 V	C	T5R4	10002
MS1H3-18C15CB-A331R-INT	MS1H3-18C15CB-A334R-INT	130	1.8	Single-phase/ Three-phase 200 V	D	S012	00007
MS1H3-18C15CD-A331R-INT	MS1H3-18C15CD-A334R-INT	130	1.8	Three-phase 400 V	D	T8R4	10003

Model Selection

Servo motor				Servo drive SV670-INT series			
Models without brake	Models with brake	Flange size (mm)	Capacity (kW)	Voltage class	Size	Model	No.
MS1H3-29C15CB-A331R-INT	MS1H3-29C15CB-A334R-INT	180	2.9	Three-phase 200 V	E	S022	00009
MS1H3-29C15CD-A331R-INT	MS1H3-29C15CD-A334R-INT	180	2.9	Three-phase 400 V	D	T012	10004
MS1H3-44C15CB-A331R-INT	MS1H3-44C15CB-A334R-INT	180	4.4	Three-phase 200 V	E	S027	00010
MS1H3-44C15CD-A331R-INT	MS1H3-44C15CD-A334R-INT	180	4.4	Three-phase 400 V		T017	10005
MS1H3-55C15CD-A331R-INT	MS1H3-55C15CD-A334R-INT	180	5.5	Three-phase 400 V		T021	10006
MS1H3-75C15CD-A331R-INT	MS1H3-75C15CD-A334R-INT	180	7.5	Three-phase 400 V		T026	10007
MS1H4 ($n_N=3000\text{rpm}$, $n_{\max}=7000\text{rpm}$)							
MS1H4-10B30CB-A330Z-INT	MS1H4-10B30CB-A332Z-INT	40	0.1	Single-phase/ Three-phase 200 V	A	S1R6	00002
MS1H4-20B30CB-A331R-INT	MS1H4-20B30CB-A334R-INT	60	0.2	Single-phase/ Three-phase 200 V			00002
MS1H4-40B30CB-A331R-INT	MS1H4-40B30CB-A334R-INT	60	0.4	Single-phase/ Three-phase 200 V		S2R8	00003
MS1H4-55B30CB-A331R-INT	-	80	0.55	Single-phase/ Three-phase 200 V	C	S5R5	00005
MS1H4-75B30CB-A331R-INT	MS1H4-75B30CB-A334R-INT	80	0.75	Single-phase/ Three-phase 200 V		S5R5	00005
MS1H4-10C30CB-A331R-INT	MS1H4-10C30CB-A334R-INT	80	1.0	Single-phase/ Three-phase 200 V	C	S7R6	00006

2 SV670N-INT Series Servo Drives

2.1 Product Information

Model description

SV670 N S 2R8 I - FS - INT
① ② ③ ④ ⑤ ⑥ ⑦

<p>① Product series SV670: SV670 general-purpose servo drive</p>	<p>④ Rated output current</p> <p>S: 200 V to 240 V</p> <p>1R6: 1.6 A 2R8: 2.8 A 5R5: 5.5 A 7R6: 7.6 A 012: 12.0 A 018: 18.0 A 022: 22.0 A 027: 27.0 A</p> <p>T: 380 V to 480 V</p> <p>3R5: 3.5 A 5R4: 5.4 A 8R4: 8.4 A 012: 12.0 A 017: 17.0 A 021: 21.0 A 026: 26.0 A</p>	<p>⑤ Model configuration I: Standard type</p>
<p>② Product type N: EtherCAT P: Pulse type + CANopen + CANlink</p>		<p>⑥ Non-standard function Blank: Standard FS: Functional safety models only come with STO</p>
<p>③ Voltage class S: 200 V to 240 V T: 380 V to 480 V</p>		<p>⑦ Model configuration INT: General (global version)</p>

Nameplate

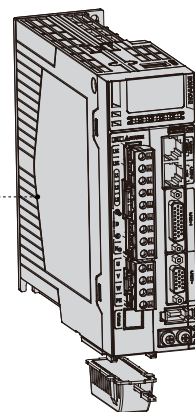
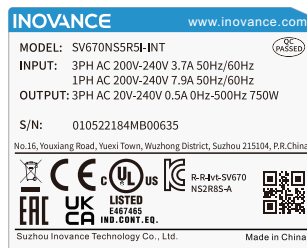

Figure 2-1 Nameplate

Encryption of the production serial number

01050202 4 P 7 00001
① ② ③ ④ ⑤

<p>① Internal code Article material code</p>	<p>③ Year 9: 2009 A: 2010 ... P: 2022 ... Note: I/L/O/Q is not used.</p>	<p>⑤ Lot number 00001: 1st in current month 00002: 2nd in current month 00003: 3rd in current month ... Range: 00001 to 99999</p>
<p>② Manufacturer code 4: Suzhou Inovance</p>	<p>④ Month 1: January 2: February ... A: October B: November C: December</p>	

Example: The S/N 010502024P700001 indicates the drive is manufactured in July, 2022.

2.1.1 Components

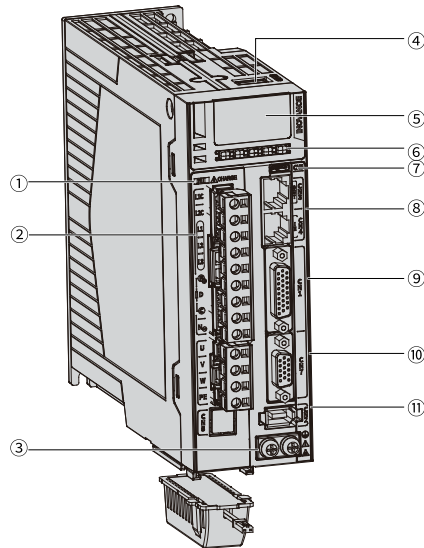

Figure 2-2 Servo drive components

Table 2-1 Description of servo drive components

No.	Name	Description
①	CHARGE (bus voltage indicator)	Indicates the electric charge is present in the bus capacitor. When the indicator turns on, charges possibly still exist in the internal capacitor of the servo unit, even if the power supply of the main circuit is OFF. To prevent electric shock, do not touch the power terminals when this indicator lights up.
②	Main circuit terminal	See section “Description of Main Circuit Terminals” in the Hardware Guide.
③	Servo drive grounding terminal	Connected to the grounding terminal of the power supply for grounding purpose.
④	CN6 STO safety function terminal ^[1]	Connected to external functional safety signal for functional safety purpose.
⑤	5-digit LED display	The 5-digit 8-segment LED display is used to show servo system's running state and parameter setting.
⑥	Keys	M: Used to switch parameters in sequence. ▲: Increases the value of the blinking bit. ▲: Decreases the value of the blinking bit. ◀◀: Shifts the blinking bit leftwards (Hold down: Turns to the next page when the displayed number exceeds five digits) S: Saves modifications and enters the next menu.
⑦	CN5 (communication terminal)	Supports online upgrade and background commissioning when the drive is powered on.
⑧	CN3, CN4 (EtherCAT communication terminals)	CN4 (IN): Connected to the master or the last slave device CN3 (OUT): Connected to the next slave device
⑨	CN1 (control terminal)	Used by reference input signals and other I/O signals.
⑩	CN7 (encoder feedback terminal)	Supports communication encoder and pulse encoder.
⑪	CN7 (encoder feedback terminal)	Connected to the motor encoder terminal.

Note

- The built-in braking resistor or jumper bar is not available in models S1R6 and S2R8. If an external braking resistor is needed for S1R6 and S2R8 models, connect it between terminals P⊕ and C.
- [1]: The CN6 STO safety function terminal is only suitable for non-standard models (-FS).

2.1.2 Product Dimensions

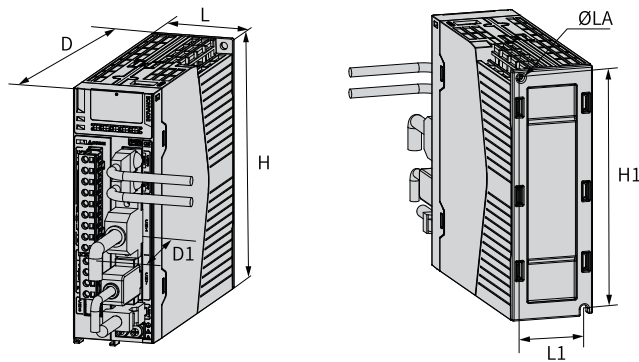

Size	L	H	D	L1	H1	D1	ØLA	Tightening torque	Weight
	Unit: mm (in.)							Unit: (N·m)	Unit: (kg)
A	45.5 (1.57)	170 (6.69)	150 (5.91)	33 (1.10)	161 (6.34)	75 (2.95)	2-M4	1.2	0.96
C	55±1 (2.17±0.04)	170 (6.69)	173±1 (6.81±0.04)	44 (1.73)	160 (6.30)	75 (2.95)	2-M4	1.2	1.3
D	80±1 (3.15±0.04)	170 (6.69)	183 (7.20)	71 (2.80)	160 (6.30)	75 (2.95)	3-M4	1.2	1.8
E	90 (3.54)	250 (9.84)	230 (9.06)	78 (3.07)	240.5 (9.47)	75 (2.95)	4-M4	1.2	3.6

2.2 Product Specifications

2.2.1 Electrical Specifications

- Single-phase 200 V drive

Item		Size A		Size C		Size D
Model		S1R6	S2R8	S5R5	S7R6	S012
Power (kW)		0.2	0.4	0.75	1.0	1.5
Max. applicable motor capacity (kW)		0.2	0.4	0.75	1.0	1.8
Power supply capacity (kVA)		1.4	2.8	4.6	6.0	8.0
Continuous output current (Arms)		1.6	2.8	5.5	7.6	12.0
Max. output current (Arms)		5.8	10.1	16.9	23.0	32.0
Main circuit	Continuous input current (Arms)	2.3	4.0	7.9	9.6	12.8
	Main circuit power supply	Single-phase 200–240 VAC, -10% to +10%, 50 Hz/60 Hz				
	Energy Loss (W) ^[1]	12	23.8	38.2	47.32	69.84

Item		Size A		Size C		Size D		
Control circuit	Control circuit power supply	Single-phase 200–240 VAC, -10% to +10%, 50 Hz/60 Hz						
	Energy Loss (W) ^[2]	16						
Braking resistor	Resistance (Ω)	Optional	Optional	50	25	25		
	Resistor power (W)	Optional	Optional	50	80	80		
	Min. resistance of external braking resistor (Ω)	40	40	40	20	15		
	Max. braking energy absorbed by capacitor (J)	9.3	18.59	32.42	32.42	47.68		
	Braking resistor	All models in the series support built-in and external braking resistors, but Size A does not come with a built-in braking resistor as standard.						
Cooling mode		Natural ventilation			Air cooling			
Overvoltage category		III						

- Three-phase 200 V drive

Item		Size A		Size C		Size D	Size E		
Model		S1R6	S2R8	S5R5	S7R6	S012	S018	S022	S027
Power (kW)		0.2	0.4	0.75	1.0	1.5	2.0	2.5	5.0
Max. applicable motor capacity (kW)		0.2	0.4	0.75	1.0	1.8	2.0	2.5	5.0
Power supply capacity (kVA)		1.21	2.42	3.84	5.05	6.68	8.33	10.42	20.08
Continuous output current (Arms)		1.6	2.8	5.5	7.6	12.0	18.0	22.0	27.0
Max. output current (Arms)		5.8	10.1	16.9	23.0	32.0	45	55	67.5
Main circuit	Continuous input current (Arms)	1.1	2.3	4.4	5.1	8.0	8.7	11.0	23.8
	Main circuit power supply	Three-phase 200–240 VAC, -10% to +10%, 50 Hz/60 Hz							
	Energy loss (W) ^[1]	12	23.8	38.2	47.32	69.84	120	125	200
Control circuit	Control circuit power supply	Single-phase 200–240 VAC, -10% to +10%, 50 Hz/60 Hz							
	Energy Loss (W) ^[2]	16							
Braking resistor	Resistance (Ω)	Optional	Optional	50	25	25	20	20	20
	Resistor power (W)	Optional	Optional	50	80	80	100	100	100
	Min. resistance of external braking resistor (Ω)	40	40	40	20	15	20	20	20
	Max. braking energy absorbed by capacitor (J)	9.3	18.59	32.42	32.42	47.68	78.19	114.43	114.43
	Braking resistor	All models in the series support built-in and external braking resistors, but Size A does not come with a built-in braking resistor as standard.					Built-in braking resistor (external braking resistor supported)		

Item	Size A	Size C	Size D	Size E
Cooling mode	Natural ventilation	Air cooling		
Overvoltage category	III			

- Three-phase 400 V drive

Item		Size C		Size D		Size E		
Model		T3R5	T5R4	T8R4	T012	T017	T021	T026
Power (kW)		1.0	1.5	2.0	3.0	5.0	6.0	7.5
Max. applicable motor capacity (kW)		1.0	1.5	2.0	3.0	4.4	5.5	7.5
Power supply capacity (kVA)		6.05	9.08	10.23	15.15	22.25	25.0	31.25
Continuous output current (Arms)		3.5	5.4	8.4	12.0	17.0	21.0	26.0
Max. output current (Arms)		11.0	14.0	20.0	30.0	42.5	52.5	65.0
Main circuit	Continuous input current (Arms)	2.4	3.6	5.6	8.0	12.0	16.0	21.0
	Main circuit power supply	Three-phase 380–480 VAC, -10% to +10%, 50 Hz/60 Hz						
	Energy loss (W) ^[1]	39.5	63.25	94.82	135.47	187.62	228.28	258.63
Control circuit	Control circuit power supply	Single-phase 380–480 VAC, -10% to +10%, 50 Hz/60 Hz						
	Energy loss (W) ^[2]	16						
Braking resistor	Resistance (Ω)	100	100	50	50	35	35	35
	Resistor power (W)	80	80	80	80	100	100	100
	Min. resistance of external braking resistor (Ω)	80	60	45	40	35	25	25
	Max. braking energy absorbed by capacitor (J)	28.23	34.28	50.41	50.41	82.67	120.98	120.98
	Braking resistor	Built-in braking resistor						
Cooling mode		Air cooling						
Overvoltage category		III						

Note

- [1] Main circuit energy loss refers to the energy loss under rated output current of the servo drive.
- [2] Control circuit energy loss refers to the energy loss under rated input current of the servo drive.
- Select the external regenerative resistor according to actual operating conditions.

2.2.2 Technical Data

Item		Description		
General Specifications	Control mode		IGBT SVPWM control, sine wave current drive mode	
			200 V, 400 V: Single-phase/Three-phase full bridge rectification	
	Encoder feedback		23-bit multi-turn absolute encoder, which can be used as an incremental encoder in absence of the battery	
	Conditions for use	Ambient/Storage temperature ^[1]		0°C to 55°C (average load ratio not exceeding 80% in ambient temperatures between 45°C to 55°C) (non freezing)/ -40°C to +70°C
		Ambient/Storage humidity		Below 90% RH (no condensation)
		Vibration resistance		Operation: <ul style="list-style-type: none"> • 5–8.4 Hz: 3.5 mm displacement • 8.4–200 Hz: 1 g Product package: <ul style="list-style-type: none"> • 5 Hz–100 Hz: 0.01 g²/Hz • 200 Hz: 0.001 g²/Hz • Grms = 1.14 g
		Shock resistance		19.6 m/s ²
		IP rating		IP20 Note: excluding terminals (IP00)
	Pollution degree		PD2	
	Altitude		The maximum altitude is 2000 m. <ul style="list-style-type: none"> • For altitudes not higher than 1000 m, derating is not required • For altitudes higher than 1000 m, Derate 1% for every additional 100 m. • For altitudes above 2000 m, contact Inovance 	
Speed/Torque control mode	Performance	Speed change ratio ^[2]	Load change ratio	Below 0.5% at 0%–100% load (under rated speed)
			Voltage change ratio	0.5% at rated voltage ±10% (under rated speed)
			Temperature change ratio	Below 0.5% at 25 ± 25°C (under rated speed)
	Speed control range		1:10000 (Under the rated torque load, the servo drive keeps running as long as the lower limit of the speed control range is not exceeded.)	
	Torque control accuracy		±2%	
	Input signal	Speed reference input	EtherCAT Communication mode	CSV/PV mode
			Analog setting; digital setting	-
		Torque reference input	EtherCAT communication mode	CST/PT mode
			Analog setting; digital setting	-

Item			Description
Position control mode	Performance	Feedforward compensation	0% to 100.0% (resolution: 0.1%)
		Timing window	1-65535 in encoder unit
	Input signal	EtherCAT communication mode	CSP mode/PP mode/HM mode
		Output mode	Phase A, phase B: differential output Phase Z: differential output or open collector output
	Position output	Frequency division ratio	Any frequency division
Input/Output signal	DI signal	DI signal function assignment	5 DIs DI1-DI3: normal DI (rising edge (24 V input low to high) input delay: 100 us, falling edge (24 V input high to low) input delay: 50 us, voltage range: 20-30 V) DI4-DI5: fast DI (rising edge (24 V input low to high) input delay: 30 us, falling edge (24 V input high to low) input delay: 5 us, voltage range: 20-30 V) The DI functions are as follows: servo enable, alarm reset, forward overtravel, reverse overtravel, electronic gear selection, home switch, emergency stop, probe
			Digital output signal
	Analog input signal		AI1 voltage input: 16-bit, -10 V to +10 V; max. allowable voltage: ±12 V AI2 voltage input: 12-bit, -10 V to +10 V; max. allowable voltage: ±12 V
	Analog output signal		AO1 voltage output range: -10 V to +10 V

Item		Description	
Built-in functions	Stop at limit switch	The servo drive stops immediately when P-OT or N-OT is active.	
	Electronic gear ratio	$0.001 \leq B/A \leq 26843545.6$	
	Protective functions	Including protections against overcurrent, overvoltage, undervoltage, overload, main circuit detection error, heatsink overheat, power phase loss, overspeed, encoder error, CPU error, and parameter error	
	STO ^[3]	Type	Input block signal of the functional safety module
		Applicable standard	IEC 61800-5-2:2016
	LED display	Main circuit CHARGE indicator, 5-digit LED display	
	Vibration suppression	5 notches (including two adaptive notches) available, 50 Hz to 8000 Hz	
	Usability functions	One-key parameter tuning, adaptive parameter tuning, intelligent parameter tuning, speed observer, and model tracking	
	Communication function	Software commissioning	Type_C
		Multi-station communication	EtherCAT
		Number of multi-station communication axes	Maximum number of slaves: 65535
		Axis address setting	No physical knob, set to 0 to 65535 through the software
		Description	Including status display, user parameter setting, monitored value display, fault tracing display, JOG and auto-tuning, speed/torque reference signal observation, and Communication and motion control command setting
Others	Gain tuning, alarm record, JOG		

Note

- [1]: Install the servo drive within the allowable ambient temperature range. When it is installed inside a control cabinet, the temperature inside the cabinet must also be within this range.
- [2]: The speed change ratio is defined by the following formula: Speed change ratio = (No-load speed - Full-load speed)/Rated speed x 100%.
- The voltage change and temperature change may result in amplifier deviation, which causes the calculated resistance value to change. Such changes is reflected by the speed change. Speed changes caused by the voltage change and the temperature change will be indicated respectively by a percentage to the rated speed.
- [3]: The STO safety function is only suitable for non-standard models (-FS).

2.2.3 Technical Data of EtherCAT Communication

	Item	Specification
Basic performance of slave	Communication protocol	EtherCAT protocol
	Service supported	CoE (PDO, SDO)
	Synchronization mode	DC - Distributed clock
	Physical layer	100BASE-TX
	Baud rate	100 Mbit/s (100Base-TX)
	Duplex mode	Full duplex
	Topology	Ring and linear
	Transmission medium	Shielded cables of Cat 5e or higher
	Transmission distance	Less than 100 m between two nodes (with proper environment and cables)
	Number of slaves	Up to 65535 by protocol, not exceeding 100 in actual use
	EtherCAT frame length	44 bytes to 1498 bytes
	Process data	A maximum of 1486 bytes per Ethernet frame
	Synchronous jitter of two slaves	< 1 us
	Update time	1000 digital input/output: 30 us About 100 μs for 100 servo axes Define different update time for different interfaces.
Communication code error rate	10 ⁻¹⁰ Ethernet standard	
Configuration unit	Number of FMMU units	8
	Number of storage synchronization management units	8
	Process data RAM	8 kB
	Distributed Clock	64-bit
	e2prom capacity	32-kbit

2.2.4 Dynamic Brake Characteristics

According to the motor model, initial speed and load inertia, the dynamic braking distance can be estimated. The approximate value of the dynamic braking distance can be calculated by the following formula. For the accurate value, please use the dynamic braking calculation function provided by our software.

Maximum braking distance s (turn) is:

$$s = \frac{V_0}{60} (t_e + (\tau_1 + \tau_2 V_0^2) (1 + \frac{J_L}{J_M}))$$

The coefficient is as follows:

$$\tau_1 = \frac{2R_s J}{3p_n^2 \Psi_f^2} = \frac{10000\pi^2 R_s J}{9K_e^2}$$

$$\tau_2 = \frac{\pi^2 L_d^2 J}{4050 R_s \Psi_f^2} = \frac{100 L_d^2 \pi^4 P_n^2 J}{243 R_s K_e^2}$$

$$\Psi_f = \frac{\sqrt{6} K_e}{100 \pi P_n}$$

- V_0 : Maximum feedback speed
- t_e : Dynamic brake program and relay delay
- J_L : Load moment of inertia
- J_M : Motor moment of inertia
- P_n : Number of motor pole pairs
- R_s : Stator resistance (Ω)
- L_q, L_d : q-axis inductance (mH), d-axis inductance (mH).

2.2.5 Load Moment of Inertia

The load moment of inertia represents the inertia of the load. The larger the load moment of inertia is, the weaker the responsiveness is. An excessively high inertia may result in unstable motion. The allowable load moment of inertia () of the motor is restricted. This value is provided strictly as a guideline and results depend on the motor driving conditions.

An overvoltage warning may occur during deceleration if the load moment of inertia exceeds the allowable value. For servo drives with a built-in regenerative resistor, an overload alarm may be present. In case of such warnings, take one of the following measures:

- Reduce the torque limit values.
- Reduce the deceleration rate.
- Reduce the maximum speed.
- Install an external braking resistor if the warning cannot be cleared using the above measures.



- Drives below 400 W does not provide a built-in braking resistor.
 - Even you use a built-in resistor, the energy generated in some conditions will exceed the allowable capacity loss (W) of the resistor. Therefore, an external braking resistor is required.
-

3 MS1-R Series Motors

3.1 Product Information

3.1.1 Model and Nameplate

Model description

MS1 H1 - 75B 30C B A3 3 1 R - *
 ① ② ③ ④ ⑤ ⑥ ⑦⑧⑨ ⑩

<p>① MS1 series servo motor</p>	<p>② Inertia and capacity</p> <p>H1: low inertia, small capacity H2: low inertia, medium capacity H3: medium inertia, medium capacity H4: medium inertia, small capacity</p>	<p>③ Rated power (W)</p> <p>One letter and two digits B: x 10 C: x 100 Example: 75B: 750 W</p>
<p>④ Rated speed (rpm)</p> <p>One letter and two digits B: x 10 C: x 100 Example: 30C: 3000 rpm</p>	<p>⑤ Voltage class (V)</p> <p>B: 220 D: 380</p>	<p>⑥ Encoder type</p> <p>One letter and one digit A3: 23-bit multi-turn absolute encoder</p>
<p>⑦ Shaft connection mode</p> <p>3: Solid shaft, with key and threaded hole</p>	<p>⑧ Brake, reducer and oil seal ^[1]</p> <p>0: No oil seal and brake 1: With oil seal but no brake 2: No oil seal but with brake 4: With oil seal and brake</p>	<p>⑨ Series</p> <p>R: R version</p> <p>⑩ Non-standard function</p> <p>Blank: standard S: Flying leads type -*: Other non-standard function</p>

Note

- [1] The standard configuration of the motor in flange size 40 does not include the oil seal. Motors of other models carry the oil seal as standard.

Nameplate

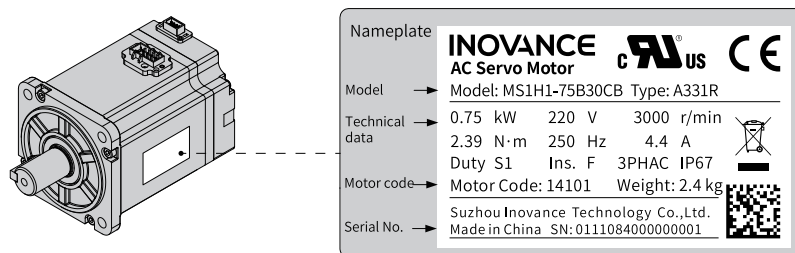

Figure 3-1 Model and Nameplate

3.1.2 Components

Motor (Flange sizes 40&60&80)

- Servo motors with terminal box

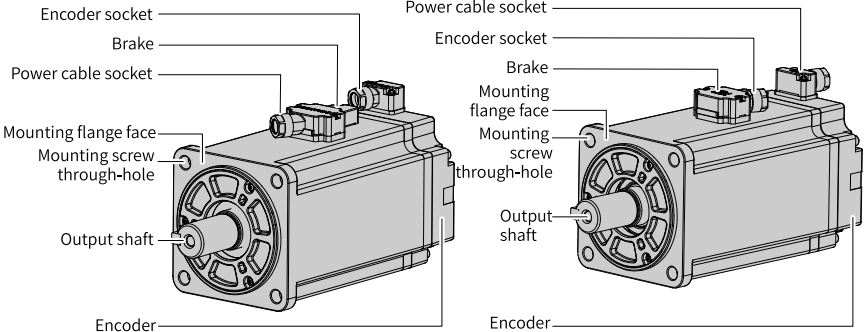

Figure 3-2 Components of motors with terminal box (left: front outlet; right: rear outlet)

- Servo motors with flying leads

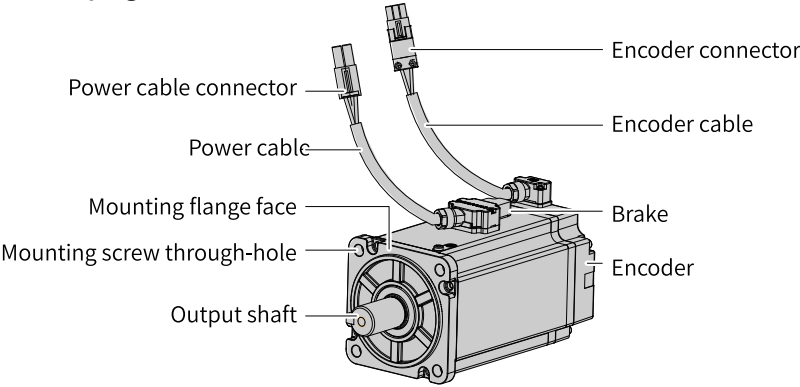

Figure 3-3 Components of motors with flying leads

Motor (Flange sizes 100&130&180)

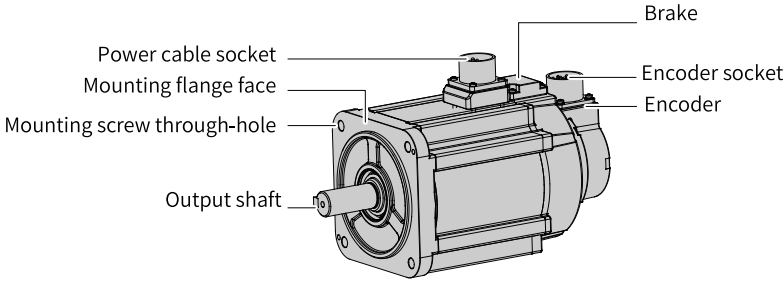





Figure 3-4 Components of servo motors in flange sizes 100/130/180

3.1.3 Motor Model

Motor type		Rated output capacity (kW)	Encoder	Enclosure protection mode
Low inertia, small capacity	 MS1H1	0.05, 0.1, 0.2, 0.4, 0.55, 0.75, 1.0	A3: 23-bit multi-turn absolute encoder	IP67
Low inertia, medium capacity	 MS1H2	1.0, 1.5, 2.0, 2.5, 3.0, 4.0, 5.0	A3: 23-bit multi-turn absolute encoder	IP67
Medium inertia, medium capacity	 MS1H3	0.85, 1.3, 1.8, 2.9, 4.4, 5.5, 7.5	A3: 23-bit multi-turn absolute encoder	IP67
Medium inertia, small capacity	 MS1H4	0.1, 0.2, 0.4, 0.55, 0.75, 1.0	A3: 23-bit multi-turn absolute encoder	IP67

3.2 Product Specifications

3.2.1 Mechanical Characteristics

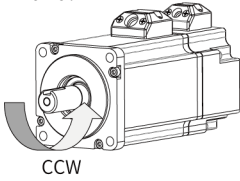
Item	Description
Duty type	S1(Continuous duty)
Vibration level ^[1]	V15
Insulation resistance	500 VDC, above 10 MΩ
Excitation mode	Permanent magnetic
Installation method	Flange type
Heat resistance level	F
Insulation voltage	1500 VAC, 1 min (220 V class) 1800 VAC, 1 min (380 V class)
IP rating of the enclosure	IP67 (excluding shaft opening and flying leads type motor connectors)
Direction of rotation	Rotates counterclockwise when viewed from the shaft extension side with the forward run command. 

Item		Description
Operating conditions	Ambient temperature	0°C to 40°C (non-freezing) (Derate based on the derating curve for temperatures above 40°C.)
	Ambient humidity	20%–80% (no condensation)
	Installation location	<ul style="list-style-type: none"> • Free from corrosive or explosive gases • Well ventilated and with minimum amount of dust, waste and moisture • Convenient for inspection and cleanup • Derating required only for altitudes above 1000 m “3.2.3 Derating Characteristics” on page 26 • Away from sources that may generate strong magnetic field • Away from heating sources such as a heating stove • Use the motor with oil seal in places with grinding fluid, oil mist, iron powders or cuttings. • The oil seal is only dust-proof. It cannot withstand the intrusion of oil in a long term. • No applicable to vacuum environment • Not applicable to inching condition, which may result in stuck • The motor with brake may generate a pattering sound. • Coupler type and installation alignment requirements • The system should avoid continuous operation at natural frequency. Exceeding the allowable vibration value may damage the system.
	Storage environment	Observe the following requirements for keeping a de-energized motor. <ul style="list-style-type: none"> • Temperature: -20°C to +60°C (non-freezing) • Humidity: 20% to 80% RH (no condensation)
Shock resistance ^[2]	Shock acceleration (taking flange side as standard)	490 m/s ²
	Times of shock	2
Vibration resistance ^[3]	Vibration acceleration (taking flange side as standard)	49 m/s ²

Note

- [1]Vibration level V15 indicates that the vibration amplitude is less than 15 μm when a single servo motor rotates at rated values.
- [2] The resistance for shock in the vertical direction when the servo motor is mounted with the shaft in a horizontal position is shown in the preceding table.
- [3] For a servo motor shaft mounted horizontally, the vibration resistance level in the up/down, left/right, and front/rear directions is shown in the preceding table.
- The strength of the vibration that the servo motor can withstand depends on the application. Check the vibration acceleration rate applied to the servo motor through the actual product.

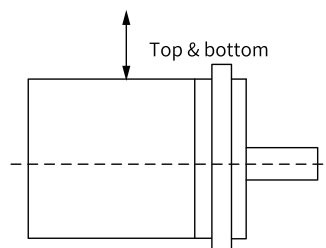

Figure 3-5 Shock applied on the motor

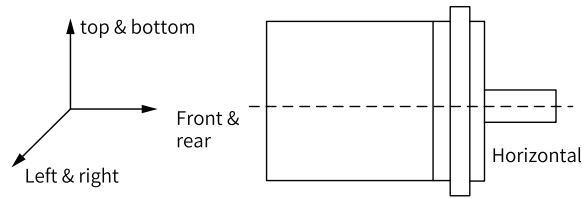

Figure 3-6 Vibration applied on the motor

3.2.2 Overload Characteristics

The equipment is compliant with NEC and CEC requirements and equipped with protective functions against overload and overtemperature.

For effective protection of different load motors, set the motor overload protection gain according to the motor overload capacity. Use the default gains in general conditions, however, when one of the following condition occurs, change the gains based on the temperature rise condition of the motor:

- The motor operates in environments with high temperature.
- The motor is in cyclic motion featuring a short motion cycle and frequent acceleration/ deceleration.
- The thermal overload protection only occurs during continuous operation. In this case, power off the drive to check the motor temperature.

The motor overload protection curve is shown in the following figure.

- **MS1H1/MS1H4**

Load ratio (%)	Operating time (s)
120	230
130	80
140	40
150	30
160	20
170	17
180	15
190	12
200	10
210	8.5
220	7
230	6
240	5.5
250	5
300	3
350	2

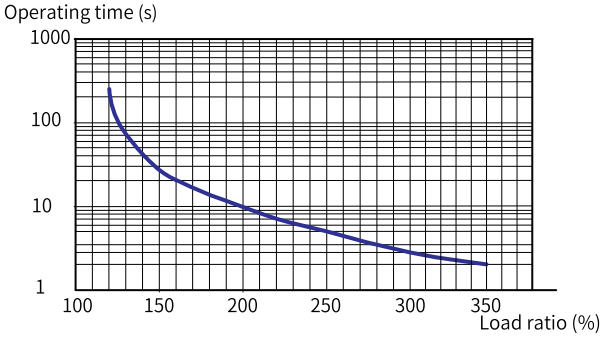

Figure 3-7 MS1H1 and MS1H4 series motor overload curves

Note

The maximum torque of MS1H1 and MS1H4 models is 3.5 times the rated torque.

• **MS1H2/MS1H3**

Load ratio (%)	Operating time (s)
115	6000
121.4	2000
127.8	1000
134.2	800
140.6	500
147	300
153.4	150
159.8	100
166.2	80
172.6	60
179.0	50
185.4	45
191.8	40
198.2	36
204.6	32
211.0	28
217.4	23
223.8	22
230.2	19
236.6	18
243.0	15
249.4	14
255.8	13
262.2	11
268.6	10
275.0	9
281.4	8
287.8	7
294.2	6

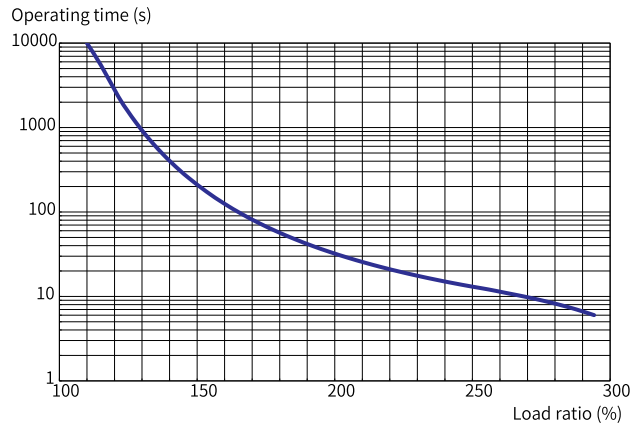

Figure 3-8 MS1H2 and MS1H3 series motor overload curves

Note

- The maximum torque of H2 models is three times the rated torque.
- The maximum torque of H3 models is 2.5 times the rated torque.

3.2.3 Derating Characteristics

- **Altitude-based derating curve**

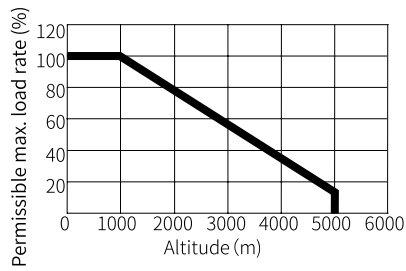

- **Temperature-based derating curve**

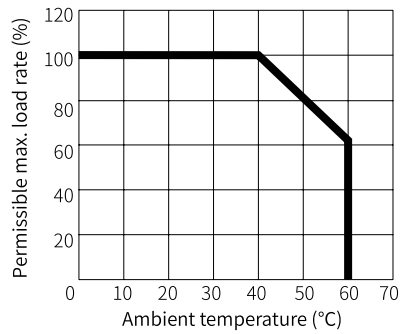

3.2.4 Temperature Curve of the Oil Seal

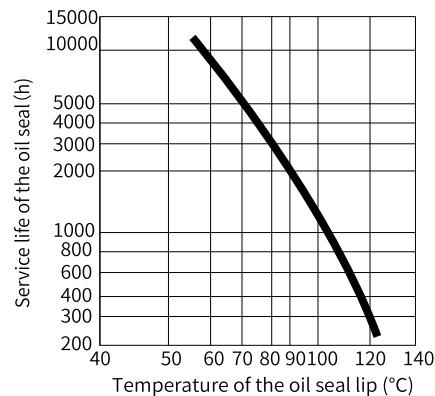

3.2.5 Load Moment of Inertia

The load moment of inertia represents the inertia of the load. The larger the load moment of inertia is, the weaker the responsiveness is. An excessively high inertia may result in unstable motion. The allowable load moment of inertia of the motor is restricted. This value is provided strictly as a guideline and varies with the motor driving conditions.

An overvoltage warning may occur during deceleration if the load moment of inertia exceeds the allowable value. For servo drives with a built-in regenerative resistor, an overload alarm may be present. In case of such alarms, take one of the following measures:

- Reduce the torque limit values.
- Reduce the deceleration rate.
- Reduce the maximum speed.
- Install an external braking resistor if the alarm cannot be cleared using the above measures.



Caution

- Check the drive selection guide for the built-in brake.
 - Even you use a built-in resistor, the energy generated in some conditions will exceed the allowable capacity loss (W) of the resistor. In this case, an external braking resistor is required.
-

3.3 Selection Instructions

- Description of torque-speed characteristic curves:
 - Technical data and torque/speed characteristic values in the following tables are applicable to motors working with Inovance servo drives with the armature coil temperature being 20°C.
 - Continuous working area: refers to a series of states in which the motor can operate safely and continuously, and the actual torque must be located in this area.
 - Short-time working area: refers to a series of states in which the motor can run in a short time when the actual torque is greater than the rated torque.

- The characteristic values are obtained in cases where the motor is installed with the following heatsink:
 - MS1H1/MS1H4: 250 x 250 x 6 (mm) (aluminum)
 - MS1H2-10C to 25C: 400 x 400 x 20 ((mm) (steel)
 - MS1H2-30C to 50C: 400 x 400 x 20 ((mm) (steel)
 - MS1H3-85B to 18C: 400 x 400 x 20 ((mm) (steel)
 - MS1H3-29C to 55C: 550 x 550 x 30 (mm) (aluminum)
 - MS1H2-50CD and MS1H3-75C: 700 x 700 x 30 (mm) (aluminum)
- Radial and axial loads of the motor:

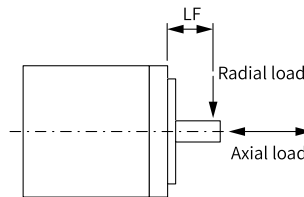

- Dimensions of flying leads type motors
The 40/60/80-flange flying leads type motor (with “-S”) provides a drain wire of about 300 mm long, as shown in the following figure.

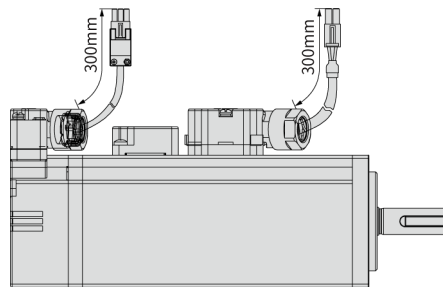

- MS1H3 (130-flange and 180-flange) comes with a key slot. When the operating speed is above 3000 rpm, the motor must run with the keyway. If you need to run the motor without the keyway at speeds higher than 3000 rpm, contact Inovance.

Note

- The motor with oil seal must be derated by 10% during use.
 - The 24 VDC power supply needs to be prepared by users. The cross sectional area of DC power cables and motor brake connection cables must be larger than 0.5mm². To prevent malfunction of the brake, use a separate power supply for the brake, preventing voltage or current drop caused by other electrical devices during operation.
 - The brake apply time and release time vary with the discharge circuit. Check the actual action delay of the product during use. The holding brake cannot be used for braking purpose.
-

3.4 Motors with Low Inertia and Small Capacity (MS1H1)

3.4.1 MS1H1-05B30CB-A33*Z-INT

Motor specifications			Torque-Speed characteristics	
Flange size (mm)	40			
Inertia, capacity	Low inertia, small capacity			
Rated power (kW)	0.05			
Rated Voltage	220			
Rated torque (N·m)	0.16			
Maximum torque (N·m)	0.56			
Rated current (Arms)	1.3			
Maximum current (Arms)	4.70			
Rated speed (rpm)	3000			
Maximum speed (rpm)	7000			
Torque coefficient (N·m/Arms)	0.15			
Rotor moment of inertia (kg·cm ²)	Motor without brake	0.026		
	Motor with brake	0.028		

Electrical specifications of the motor with brake

Holding Torque (N·m)	Supply voltage (VDC) ±10%	Rated power (W)	Coil resistance (Ω)(±7%)	Exciting current (A)	Apply time (ms)	Release time (ms)	Backlash (°)
0.32	24	6.1	94.4	0.25	≤ 40	≤ 20	≤ 1.5

Allowable load

LF (mm)	Allowable radial load (N)	Allowable axial load (N)
20	78	54

Dimensions (mm)

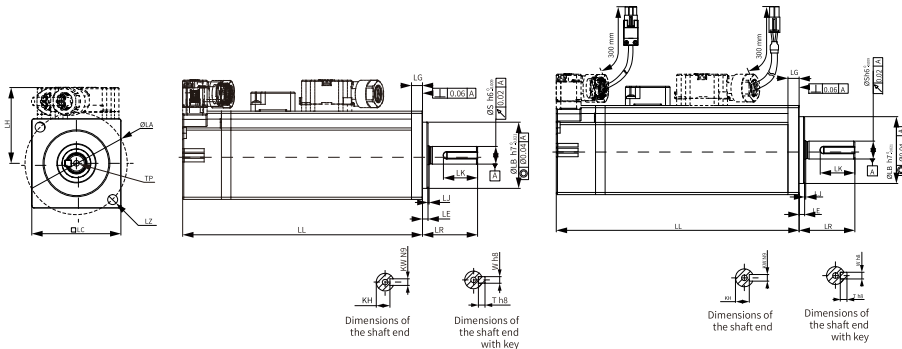

LL	LC	LR	LA	LZ	LH	LG	LE	LJ
65.4 (96)	40	25±0.3	46	2-Ø4.5	34.3	5	2.5 ± 0.5	0.5±0.35
S	LB	TP	LK	KH	KW	W	T	Weight (kg)
8	Ø30h7 ⁰ -0.021	M3x6	15.5	6.2- ⁰ 0.1	3	3	3	0.39 (0.50)

3.4.2 MS1H1-10B30CB-A33*Z-INT

Motor specifications			Torque-Speed characteristics	
Flange size (mm)	40			
Inertia, capacity	Low inertia, small capacity			
Rated power (kW)	0.1			
Rated Voltage	220			
Rated torque (N·m)	0.32			
Maximum torque (N·m)	1.12			
Rated current (Arms)	1.3			
Maximum current (Arms)	4.70			
Rated speed (rpm)	3000			
Maximum speed (rpm)	7000			
Torque coefficient (N·m/Arms)	0.26			
Rotor moment of inertia (kg·cm ²)	Motor without brake	0.041		
	Motor with brake	0.043		

Electrical specifications of the motor with brake

Holding Torque (N·m)	Supply voltage (VDC) ±10%	Rated power (W)	Coil resistance (Ω) (±7%)	Exciting current (A)	Apply time (ms)	Release time (ms)	Backlash (°)
0.32	24	6.1	94.4	0.25	≤ 40	≤ 20	≤ 1.5

Allowable load

LF (mm)	Allowable radial load (N)	Allowable axial load (N)
20	78	54

Dimensions (mm)

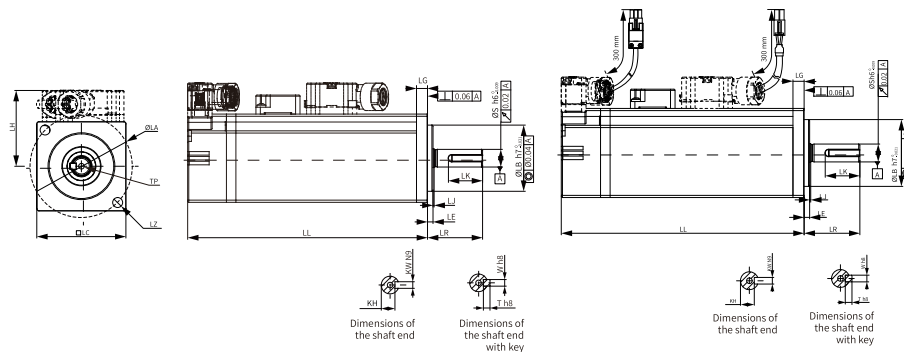

LL	LC	LR	LA	LZ	LH	LG	LE	LJ
78.4 (110)	40	25±0.3	46	2-Ø4.5	34.3	5	2.5 ± 0.5	0.5±0.35
S	LB	TP	LK	KH	KW	W	T	Weight (kg)
8	Ø30h7 ⁰ -0.021	M3x6	15.5	6.2- ⁰ 0.1	3	3	3	0.45 (0.64)

3.4.3 MS1H1-20B30CB-A33*R-INT

Motor specifications			Torque-Speed characteristics	
Flange size (mm)	60			
Inertia, capacity	Low inertia, small capacity			
Rated power (kW)	0.2			
Voltage (V)	220			
Rated torque (N·m)	0.64			
Maximum torque (N·m)	2.24			
Rated current (Arms)	1.5			
Maximum current (Arms)	5.8			
Rated speed (rpm)	3000			
Maximum speed (rpm)	7000			
Torque coefficient (N·m/Arms)	0.46			
Rotor moment of inertia (kg·cm ²)	Motor without brake	0.094		
	Motor with brake	0.106		

Electrical specifications of the motor with brake

Holding torque (N·m)	Supply voltage (VDC)±10%	Rated power (W)	Coil resistance (Ω) (±7%)	Exciting current (A)	Apply time (ms)	Release time (ms)	Backlash (°)
1.5	24	7.6	75.79	0.32	≤ 60	≤ 20	≤ 1.5

Allowable load

LF (mm)	Allowable radial load (N)	Allowable axial load (N)
25	245	74

Dimensions (mm)

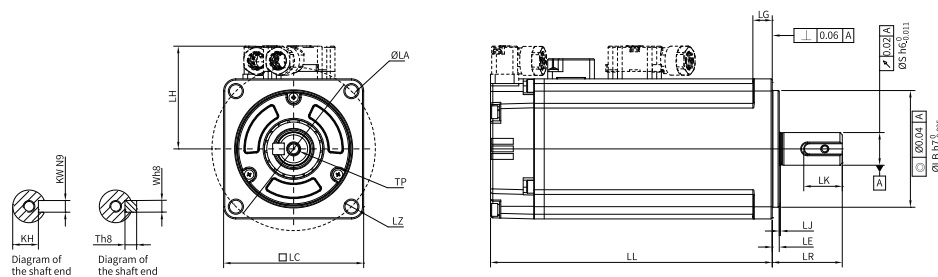

LC	LL	LR	LA	LZ	LH	LG	LE	LJ
60	75.5 (103)	30±0.5	70	4-Ø 5.5	44	8.0	3±0.5	0.5±0.35
LB	S	TP	LK	KH	KW	W	T	Weight (kg)
Ø50h7 ⁰ -0.025	14	M5x8	16.5	11 ⁰ -0.1	5	5	5	0.80 (1.17)

3.4.4 MS1H1-40B30CB-A33*R-INT

Motor specifications			Torque-Speed characteristics
Flange size (mm)	60		
Inertia, capacity	Low inertia, small capacity		
Rated power (kW)	0.4		
Voltage (V)	220		
Rated torque (N·m)	1.27		
Maximum torque (N·m)	4.45		
Rated current (Arms)	2.5		
Maximum current (Arms)	9.8		
Rated speed (rpm)	3000		
Maximum speed (rpm)	7000		
Torque coefficient (N·m/Arms)	0.53		Heatsink-based derating curve
Rotor moment of inertia (kg·cm ²)	Motor without brake	0.145	
	Motor with brake	0.157	

Electrical specifications of the motor with brake

Holding torque (N·m)	Supply voltage (VDC)±10%	Rated power (W)	Coil resistance (Ω) (±7%)	Exciting current (A)	Apply time (ms)	Release time (ms)	Backlash (°)
1.5	24	7.6	75.79	0.32	≤ 60	≤ 20	≤ 1.5

Allowable load

LF (mm)	Allowable radial load (N)	Allowable axial load (N)
25	245	74

Dimensions (mm)

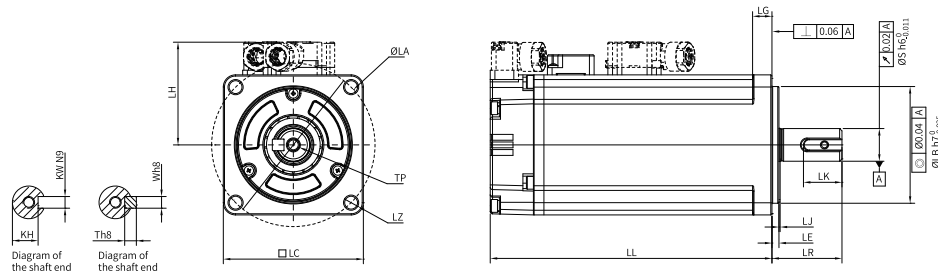

LC	LL	LR	LA	LZ	LH	LG	LE	LJ
60	93 (121)	30 ± 0.5	70	4-Ø 5.5	44	8.0	3 ± 0.5	0.5±0.35
LB	S	TP	LK	KH	KW	W	T	Weight (kg)
Ø50h7 ⁰ -0.025	14	M5x8	16.5	11 ⁰ -0.1	5	5	5	1.11 (1.48)

3.4.5 MS1H1-55B30CB-A33*R-INT

Motor specifications		Torque-Speed characteristics		
Flange size (mm)	80			
Inertia, capacity	Low inertia, small capacity			
Rated power (kW)	0.55			
Voltage (V)	220			
Rated torque (N·m)	1.75			
Maximum torque (N·m)	6.13			
Rated current (Arms)	3.9			
Maximum current (Arms)	15			
Rated speed (rpm)	3000			
Maximum speed (rpm)	7000			
Torque coefficient (N·m/Arms)	0.49			
Rotor moment of inertia (kg·cm ²)	Motor without brake			0.55
	Motor with brake			-

Allowable load

LF (mm)	Allowable radial load (N)	Allowable axial load (N)
35	392	147

Dimensions (mm)

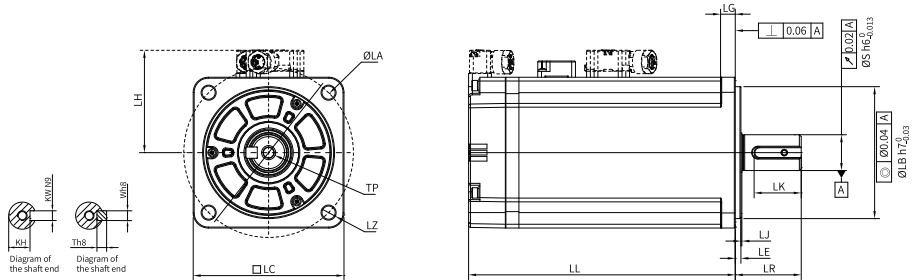

LC	LL	LR	LA	LZ	LH	LG	LE	LJ
80	96.7	25±0.5	90	4-Ø7	54	7.5	3±0.5	0.5±0.35
LB	S	TP	LK	KH	KW	W	T	Weight (kg)
Ø70h7 ⁰ _{-0.03}	19	M6 x 20	26	15.5 ⁰ _{-0.1}	6	6	6	1.88

3.4.6 MS1H1-75B30CB-A33*R-INT

Motor specifications			Torque-Speed characteristics	
Flange size (mm)	80			
Inertia, capacity	Low inertia, small capacity			
Rated power (kW)	0.75			
Voltage (V)	220			
Rated torque (N·m)	2.39			
Maximum torque (N·m)	8.37			
Rated current (Arms)	4.4			
Maximum current (Arms)	16.9			
Rated speed (rpm)	3000			
Maximum speed (rpm)	7000			
Torque coefficient (N·m/Arms)	0.58			
Rotor moment of inertia (kg·cm ²)	Motor without brake	0.68		
	Motor with brake	0.71		

Electrical specifications of the motor with brake

Holding torque (N·m)	Supply voltage (VDC) ±10%	Rated power (W)	Coil resistance (Ω) (±7%)	Exciting current (A)	Apply time (ms)	Release time (ms)	Backlash (°)
3.2	24	10	57.6	0.42	≤ 60	≤ 40	≤ 1

Allowable load

LF (mm)	Allowable radial load (N)	Allowable axial load (N)
35	392	147

Dimensions (mm)

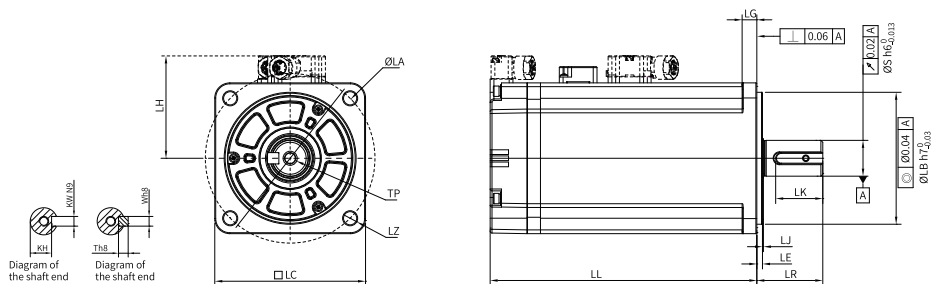

LC	LL	LR	LA	LZ	LH	LG	LE	LJ
80	107.3 (141.5)	25 ± 0.5	90	4- Ø 7	54	7.5	3 ± 0.5	0.5 ± 0.35
LB	S	TP	LK	KH	KW	W	T	Weight (kg)
Ø70h7 ⁰ -0.03	19	M6 × 20	26	15.5 ⁰ -0.1	6	6	6	2.22 (2.88)

3.4.7 MS1H1-10C30CB-A33*R-INT

Motor specifications			Torque-Speed characteristics	
Flange size (mm)	80			
Inertia, capacity	Low inertia, small capacity			
Rated power (kW)	1.0			
Voltage (V)	220			
Rated torque (N·m)	3.18			
Maximum torque (N·m)	11.13			
Rated current (Arms)	6.2			
Maximum current (Arms)	24			
Rated speed (rpm)	3000			
Maximum speed (rpm)	7000			
Torque coefficient (N·m/Arms)	0.46			
Rotor moment of inertia (kg·cm ²)	Motor without brake	0.82		
	Motor with brake	0.87		

Electrical specifications of the motor with brake

Holding torque (N·m)	Supply voltage (VDC)±10%	Rated power (W)	Coil resistance (Ω) (±7%)	Exciting current (A)	Apply time (ms)	Release time (ms)	Backlash (°)
3.2	24	10	57.6	0.42	≤ 60	≤ 40	≤ 1

Allowable load

LF (mm)	Allowable radial load (N)	Allowable axial load (N)
35	392	147

Dimensions (mm)

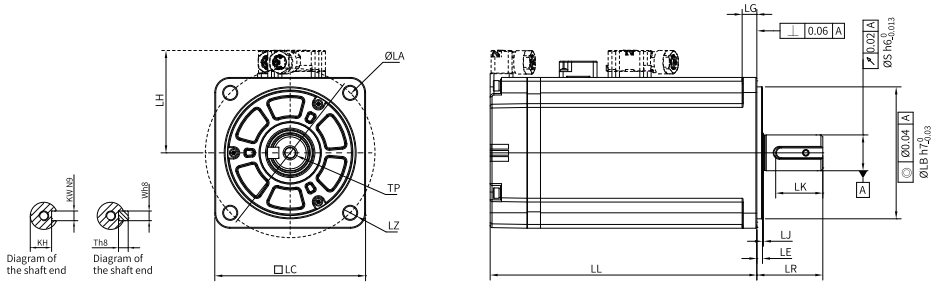

LC	LL	LR	LA	LZ	LH	LG	LE	LJ
80	119.2 (153.4)	25±0.5	90	4- Ø 7	54	7.5	3 ± 0.5	0.5±0.35
LB	S	TP	LK	KH	KW	W	T	Weight (kg)
Ø 70h7 ⁰ _{-0.03}	19	M6 × 20	26	15.5 ⁰ _{-0.1}	6	6	6	2.61 (3.27)

3.5 Motors with Low Inertia and Medium Capacity (MS1H2)

3.5.1 MS1H2-10C30CB-A33*R-INT

Motor specifications		Torque-Speed characteristics	
Flange size (mm)	100		
Inertia, capacity	Low inertia, medium capacity		
Rated power (kW)	1.0		
Voltage (V)	220		
Rated torque (N·m)	3.18		
Maximum torque (N·m)	9.54		
Rated current (Arms)	6.4		
Maximum current (Arms)	23		
Rated speed (rpm)	3000		
Maximum speed (rpm)	6000		
Torque coefficient (N·m/Arms)	0.54		
Rotor moment of inertia (kg·cm ²)	Motor without brake		
	Motor with brake	2.6	

Electrical specifications of the motor with brake

Holding torque (N·m)	Supply voltage (VDC) ±10%	Rated power (W)	Coil resistance (Ω) (±7%)	Exciting current (A)	Apply time (ms)	Release time (ms)	Backlash (°)
8	24	17.6	32.73	0.73	≤ 100	≤ 40	≤ 1

Allowable load

LF (mm)	Allowable radial load (N)	Allowable axial load (N)
45	686	196

Dimensions (mm)

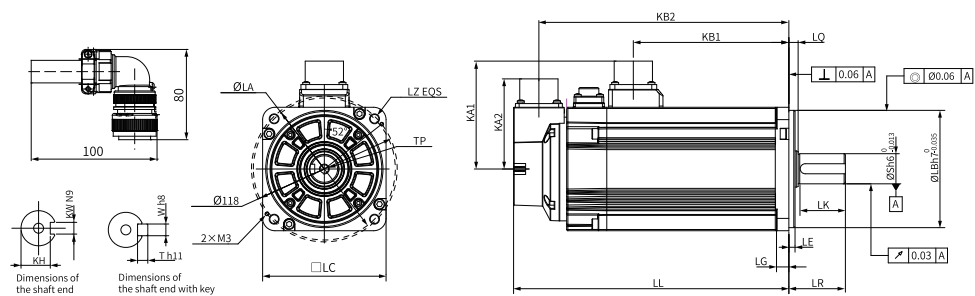

LC	LL	LR	LA	LZ	KA1	KB1	KA2	KB2	LG	LE
100	144 (172)	45 ± 1	115	4-Ø7	88	75	73	123.5 (151.5)	10	5 ± 0.3
LQ	LB	S	TP	LK	KH	KW	W	T	Weight (kg)	
7.5 ± 0.75	Ø95h7 ⁰ -0.035	24	M8x16	36	20 ⁰ -0.2	8	8	7	3.85 (4.9)	

3.5.2 MS1H2-10C30CD-A33*R-INT

Motor specifications			Torque-Speed characteristics	
Flange size (mm)	100			
Inertia, capacity	Low inertia, medium capacity			
Rated power (kW)	1.0			
Voltage (V)	380			
Rated torque (N·m)	3.18			
Maximum torque (N·m)	9.54			
Rated current (Arms)	3.3			
Maximum current (Arms)	11			
Rated speed (rpm)	3000			
Maximum speed (rpm)	6000			
Torque coefficient (N·m/Arms)	1.07			
Rotor moment of inertia (kg·cm ²)	Motor without brake	1.78		
	Motor with brake	2.6		

Electrical specifications of the motor with brake

Holding torque (N·m)	Supply voltage (VDC)±10%	Rated power (W)	Coil resistance (Ω) (±7%)	Exciting current (A)	Apply time (ms)	Release time (ms)	Backlash (°)
8	24	17.6	32.73	0.73	≤ 100	≤ 40	≤ 1

Allowable load

LF (mm)	Allowable radial load (N)	Allowable axial load (N)
45	686	196

Dimensions (mm)

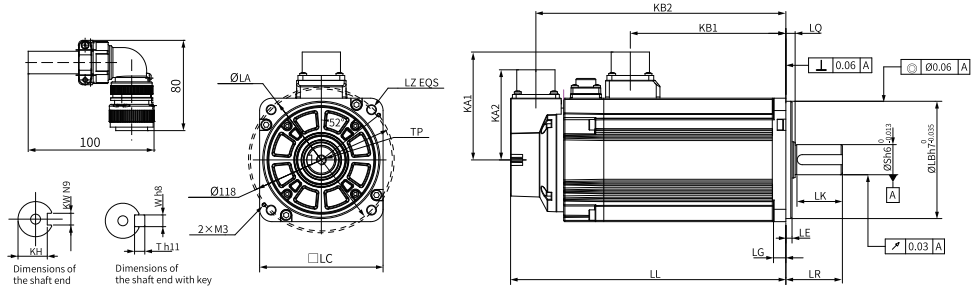

LC	LL	LR	LA	LZ	KA1	KB1	KA2	KB2	LG	LE
100	144 (172)	45±1	115	4-Ø7	88	75	73	123.5 (151.5)	10	5±0.3
LQ	LB		S	TP	LK	KH	KW	W	T	Weight (kg)
7.5±0.75	Ø95h7 ⁰ -0.035		24	M8x16	36	20 ⁰ -0.2	8	8	7	3.85 (4.9)

3.5.3 MS1H2-15C30CB-A33*R-INT

Motor specifications			Torque-Speed characteristics	
Flange size (mm)	100			
Inertia, capacity	Low inertia, medium capacity			
Rated power (kW)	1.5			
Voltage (V)	220			
Rated torque (N·m)	4.9			
Maximum torque (N·m)	14.7			
Rated current (Arms)	8.6			
Maximum current (Arms)	32			
Rated speed (rpm)	3000			
Maximum speed (rpm)	6000			
Torque coefficient (N·m/Arms)	0.62		Heatsink-based derating curve 	
Rotor moment of inertia (kg·cm ²)	Motor without brake	2.35		
	Motor with brake	3.17		

Electrical specifications of the motor with brake

Holding torque (N·m)	Supply voltage (VDC) ±10%	Rated power (W)	Coil resistance (Ω) (±7%)	Exciting current (A)	Apply time (ms)	Release time (ms)	Backlash (°)
8	24	17.6	32.73	0.73	≤ 100	≤ 40	≤ 1

Allowable load

LF (mm)	Allowable radial load (N)	Allowable axial load (N)
45	686	196

Dimensions (mm)

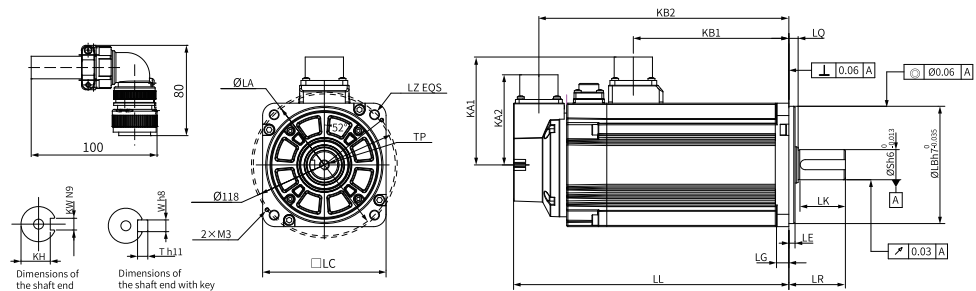

LC	LL	LR	LA	LZ	KA1	KB1	KA2	KB2	LG	LE
100	161 (189)	45 ± 1	115	4-Ø7	88	92	73	140.5 (168.5)	10	5 ± 0.3
LQ	LB		S	TP	LK	KH	KW	W	T	Weight (kg)
7.5 ± 0.75	Ø95h7 ⁰ -0.035		24	M8x16	36	20 ⁰ -0.2	8	8	7	4.65 (5.75)

3.5.4 MS1H2-15C30CD-A33*R-INT

Motor specifications			Torque-Speed characteristics	
Flange size (mm)	100			
Inertia, capacity	Low inertia, medium capacity			
Rated power (kW)	1.5			
Voltage (V)	380			
Rated torque (N·m)	4.9			
Maximum torque (N·m)	14.7			
Rated current (Arms)	4.2			
Maximum current (Arms)	14			
Rated speed (rpm)	3000			
Maximum speed (rpm)	6000			
Torque coefficient (N·m/Arms)	1.28			
Rotor moment of inertia (kg·cm ²)	Motor without brake	2.35		
	Motor with brake	3.17		

Electrical specifications of the motor with brake

Holding torque (N·m)	Supply voltage (VDC)±10%	Rated power (W)	Coil resistance (Ω) (±7%)	Exciting current (A)	Apply time (ms)	Release time (ms)	Backlash (°)
8	24	17.6	32.73	0.73	≤ 100	≤ 40	≤ 1

Allowable load

LF (mm)	Allowable radial load (N)	Allowable axial load (N)
45	686	196

Dimensions (mm)

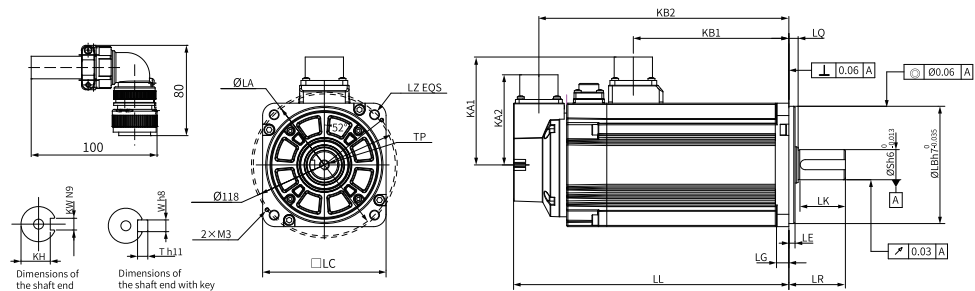

LC	LL	LR	LA	LZ	KA1	KB1	KA2	KB2	LG	LE
100	161 (189)	45±1	115	4-Ø7	88	92	73	140.5 (168.5)	10	5±0.3
LQ	LB		S	TP	LK	KH	KW	W	T	Weight (kg)
7.5±0.75	Ø95h7 ⁰ -0.035		24	M8x16	36	20 ⁰ -0.2	8	8	7	4.65 (5.75)

3.5.5 MS1H2-20C30CB-A33*R-INT

Motor specifications			Torque-Speed characteristics	
Flange size (mm)	100			
Inertia, capacity	Low inertia, medium capacity			
Rated power (kW)	2.0			
Voltage (V)	220			
Rated torque (N·m)	6.36			
Maximum torque (N·m)	19.1			
Rated current (Arms)	11.3			
Maximum current (Arms)	42			
Rated speed (rpm)	3000			
Maximum speed (rpm)	6000			
Torque coefficient (N·m/Arms)	0.60			
Rotor moment of inertia (kg·cm ²)	Motor without brake	2.92		
	Motor with brake	3.74		

Electrical specifications of the motor with brake

Holding torque (N·m)	Supply voltage (VDC) ±10%	Rated power (W)	Coil resistance (Ω) (±7%)	Exciting current (A)	Apply time (ms)	Release time (ms)	Backlash (°)
8	24	17.6	32.73	0.73	≤ 100	≤ 40	≤ 1

Allowable load

LF (mm)	Allowable radial load (N)	Allowable axial load (N)
45	686	196

Dimensions (mm)

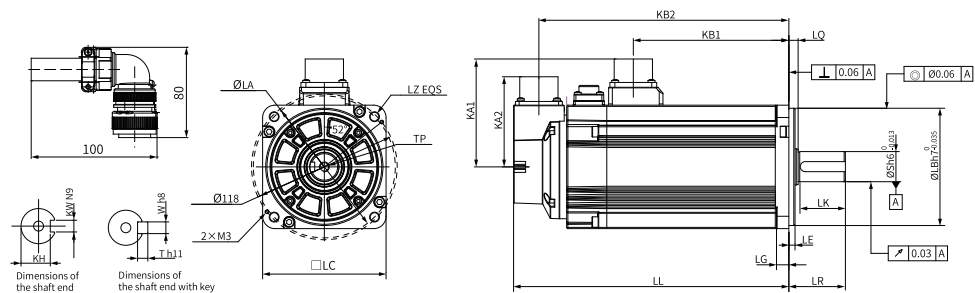

LC	LL	LR	LA	LZ	KA1	KB1	KA2	KB2	LG	LE
100	177 (205)	45 ± 1	115	4-Ø7	88	108	73	156.5 (184.5)	10	5 ± 0.3
LJ	LB		S	TP	LK	KH	KW	W	T	Weight (kg)
7.5 ± 0.75	Ø95h7 ⁰ _{-0.035}		24	M8x16	36	20 ⁰ _{-0.2}	8	8	7	5.5 (6.55)

3.5.6 MS1H2-20C30CD-A33*R-INT

Motor specifications			Torque-Speed characteristics	
Flange size (mm)	100			
Inertia, capacity	Low inertia, medium capacity			
Rated power (kW)	2.0			
Voltage (V)	380			
Rated torque (N·m)	6.36			
Maximum torque (N·m)	19.1			
Rated current (Arms)	5.6			
Maximum current (Arms)	20			
Rated speed (rpm)	3000			
Maximum speed (rpm)	6000			
Torque coefficient (N·m/Arms)	1.19			
Rotor moment of inertia (kg·cm ²)	Motor without brake	2.92		
	Motor with brake	3.74		

Electrical specifications of the motor with brake

Holding torque (N·m)	Supply voltage (VDC)±10%	Rated power (W)	Coil resistance (Ω) (±7%)	Exciting current (A)	Apply time (ms)	Release time (ms)	Backlash (°)
8	24	17.6	32.73	0.73	≤ 100	≤ 40	≤ 1

Allowable load

LF (mm)	Allowable radial load (N)	Allowable axial load (N)
45	686	196

Dimensions (mm)

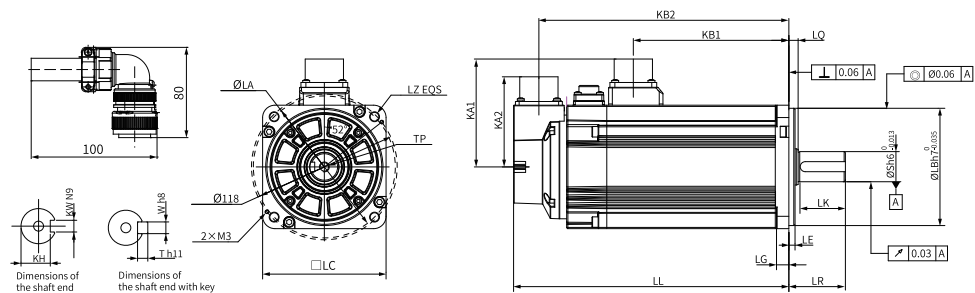

LC	LL	LR	LA	LZ	KA1	KB1	KA2	KB2	LG	LE
100	177 (205)	45±1	115	4-Ø7	88	108	73	156.5 (184.5)	10	5±0.3
LJ	LB		S	TP	LK	KH	KW	W	T	Weight (kg)
7.5±0.75	Ø95h7 ⁰ -0.035		24	M8x16	36	20 ⁰ -0.2	8	8	7	5.5 (6.55)

3.5.7 MS1H2-25C30CB-A33*R-INT

Motor specifications			Torque-Speed characteristics	
Flange size (mm)	100			
Inertia, capacity	Low inertia, medium capacity			
Rated power (kW)	2.5			
Voltage (V)	220			
Rated torque (N·m)	7.96			
Maximum torque (N·m)	23.9			
Rated current (Arms)	14.7			
Maximum current (Arms)	53			
Rated speed (rpm)	3000			
Maximum speed (rpm)	6000			
Torque coefficient (N·m/Arms)	0.60			
Rotor moment of inertia (kg·cm ²)	Motor without brake	3.49		
	Motor with brake	4.3		

Electrical specifications of the motor with brake

Holding torque (N·m)	Supply voltage (VDC) ±10%	Rated power (W)	Coil resistance (Ω) (±7%)	Exciting current (A)	Apply time (ms)	Release time (ms)	Backlash (°)
8	24	17.6	32.73	0.73	≤ 100	≤ 40	≤ 1

Allowable load

LF (mm)	Allowable radial load (N)	Allowable axial load (N)
45	686	196

Dimensions (mm)

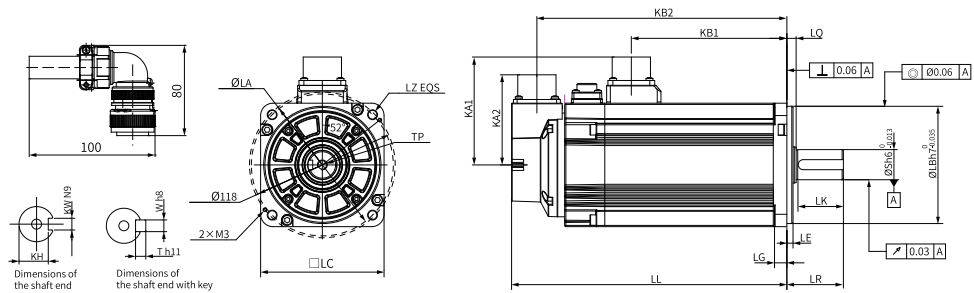

LC	LL	LR	LA	LZ	KA1	KB1	KA2	KB2	LG	LE
100	195 (223)	45 ± 1	115	4-Ø7	88	126	73	174.5 (202.5)	10	5 ± 0.3
LQ	LB		S	TP	LK	KH	KW	W	T	Weight (kg)
7.5 ± 0.75	Ø95h7 ⁰ -0.035		24	M8x16	36	20 ⁰ -0.2	8	8	7	6.3 (7.35)

3.5.8 MS1H2-25C30CD-A33*R-INT

Motor specifications			Torque-Speed characteristics	
Flange size (mm)	100			
Inertia, capacity	Low inertia, medium capacity			
Rated power (kW)	2.5			
Voltage (V)	380			
Rated torque (N·m)	7.96			
Maximum torque (N·m)	23.9			
Rated current (Arms)	7.2			
Maximum current (Arms)	26			
Rated speed (rpm)	3000			
Maximum speed (rpm)	6000			
Torque coefficient (N·m/Arms)	1.18			
Rotor moment of inertia (kg·cm ²)	Motor without brake	3.49		
	Motor with brake	4.3		

Electrical specifications of the motor with brake

Holding torque (N·m)	Supply voltage (VDC)±10%	Rated power (W)	Coil resistance (Ω) (±7%)	Exciting current (A)	Apply time (ms)	Release time (ms)	Backlash (°)
8	24	17.6	32.73	0.73	≤ 100	≤ 40	≤ 1

Allowable load

LF (mm)	Allowable radial load (N)	Allowable axial load (N)
45	686	196

Dimensions (mm)

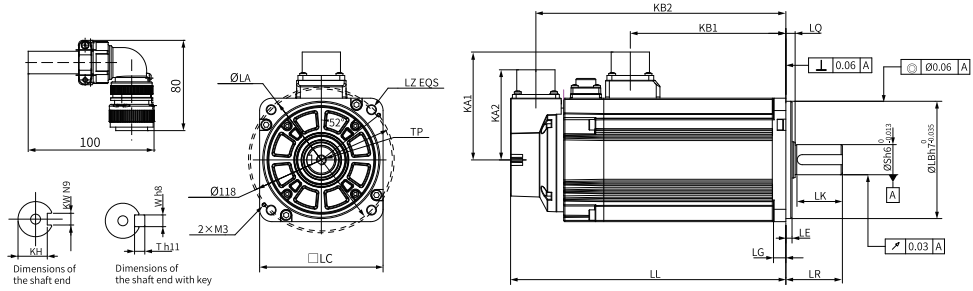

LC	LL	LR	LA	LZ	KA1	KB1	KA2	KB2	LG	LE
100	195 (223)	45±1	115	4-Ø7	88	126	73	174.5 (202.5)	10	5±0.3
LQ	LB		S	TP	LK	KH	KW	W	T	Weight (kg)
7.5±0.75	Ø95h7 ⁰ -0.035		24	M8x16	36	20 ⁰ -0.2	8	8	7	6.3 (7.35)

3.5.9 MS1H2-30C30CB-A33*R-INT

Motor specifications		Torque-Speed characteristics		
Flange size (mm)	130	<p>— A Continuous duty zone — B Intermittent duty zone</p>		
Inertia, capacity	Low inertia, medium capacity			
Rated power (kW)	3.0			
Voltage (V)	220			
Rated torque (N·m)	9.8			
Maximum torque (N·m)	24.5			
Rated current (Arms)	16.6			
Maximum current (Arms)	55			
Rated speed (rpm)	3000			
Maximum speed (rpm)	6000			
Torque coefficient (N·m/Arms)	0.67	<p>Max. allowable load rate (%)</p> <p>Heatsink dimensions (mm)</p>		
Rotor moment of inertia (kg·cm ²)	Motor without brake			6.4
	Motor with brake			9.38

Electrical specifications of the motor with brake

Holding torque (N·m)	Supply voltage (VDC) ±10%	Rated power (W)	Coil resistance (Ω) (±7%)	Exciting current (A)	Apply time (ms)	Release time (ms)	Backlash (°)
16	24	24	24	1	≤ 120	≤ 60	≤ 1

Allowable load

LF (mm)	Allowable radial load (N)	Allowable axial load (N)
63	1176	392

Dimensions (mm)

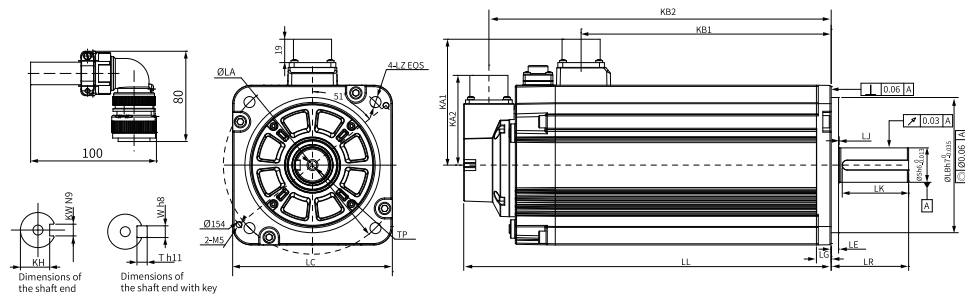

LC	LL	LR	LA	LZ	KA1	KB1	KA2	KB2	LG	LE
130	198 (223)	63 ± 1	145	4-Ø9	102.4	127.5	73	177.5 (202.5)	12	6 ± 0.3
LJ	LB		S	TP	LK	KH	KW	W	T	Weight (kg)
0.5 ± 0.75	Ø110h7 ⁰ _{-0.035}		28	M8 × 20	54	24 ⁰ _{-0.2}	8	8	7	10.0 (11.9)

3.5.10 MS1H2-30C30CD-A33*R-INT

Motor specifications		Torque-Speed characteristics		
Flange size (mm)	130	<p>— A Continuous duty zone — B Intermittent duty zone</p>		
Inertia, capacity	Low inertia, medium capacity			
Rated power (kW)	3.0			
Voltage (V)	380			
Rated torque (N·m)	9.8			
Maximum torque (N·m)	29.4			
Rated current (Arms)	8.9			
Maximum current (Arms)	29			
Rated speed (rpm)	3000			
Maximum speed (rpm)	6000			
Torque coefficient (N·m/Arms)	1.25	<p>Max. allowable load rate (%)</p> <p>Heatsink dimensions (mm)</p>		
Rotor moment of inertia (kg·cm ²)	Motor without brake			6.4
	Motor with brake			9.38

Electrical specifications of the motor with brake

Holding torque (N·m)	Supply voltage (VDC)±10%	Rated power (W)	Coil resistance (Ω) (±7%)	Exciting current (A)	Apply time (ms)	Release time (ms)	Backlash (°)
16	24	24	24	1	≤ 120	≤ 60	≤ 1

Allowable load

LF (mm)	Allowable radial load (N)	Allowable axial load (N)
63	1176	392

Dimensions (mm)

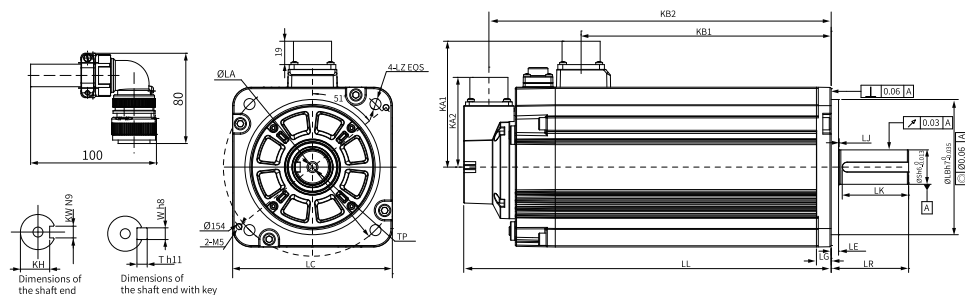

LC	LL	LR	LA	LZ	KA1	KB1	KA2	KB2	LG	LE
130	198 (223)	63±1	145	4-Ø9	102.4	127.5	73	177.5 (202.5)	12	6±0.3
LJ	LB		S	TP	LK	KH	KW	W	T	Weight (kg)
0.5±0.75	Ø110h7 ⁰ _{-0.035}		28	M8 × 20	54	24 ⁰ _{-0.2}	8	8	7	10.0 (11.9)

3.5.11 MS1H2-40C30CB-A33*R-INT

Motor specifications		Torque-Speed characteristics		
Flange size (mm)	130			
Inertia, capacity	Low inertia, medium capacity			
Rated power (kW)	4.0			
Voltage (V)	220			
Rated torque (N·m)	12.6			
Maximum torque (N·m)	31.5			
Rated current (Arms)	22			
Maximum current (Arms)	67.5			
Rated speed (rpm)	3000			
Maximum speed (rpm)	6000			
Torque coefficient (N·m/Arms)	0.65			
Rotor moment of inertia (kg·cm ²)	Motor without brake			9
	Motor with brake			11.98

Electrical specifications of the motor with brake

Holding torque (N·m)	Supply voltage (VDC)±10%	Rated power (W)	Coil resistance (Ω) (±7%)	Exciting current (A)	Apply time (ms)	Release time (ms)	Backlash (°)
16	24	24	24	1	≤ 120	≤ 60	≤ 1

Allowable load

LF (mm)	Allowable radial load (N)	Allowable axial load (N)
63	1176	392

Dimensions (mm)

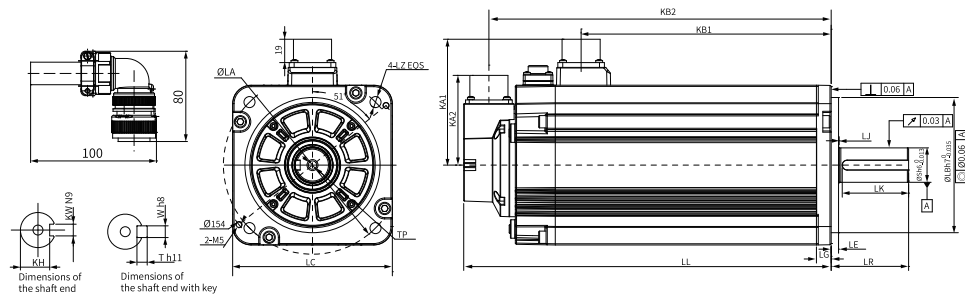

LC	LL	LR	LA	LZ	KA1	KB1	KA2	KB2	LG	LE
130	236 (261)	63±1	145	4-Ø9	102.4	165.5	73	215.5 (240.5)	12	6±0.3
LJ	LB		S	TP	LK	KH	KW	W	T	Weight (kg)
0.5±0.75	Ø110h7 ⁰ _{-0.035}		28	M8 × 20	54	24 ⁰ _{-0.2}	8	8	7	13.2 (15.1)

3.5.12 MS1H2-40C30CD-A33*R-INT

Motor specifications		Torque-Speed characteristics		
Flange size (mm)	130			
Inertia, capacity	Low inertia, medium capacity			
Rated power (kW)	4.0			
Voltage (V)	380			
Rated torque (N·m)	12.6			
Maximum torque (N·m)	37.8			
Rated current (Arms)	13.5			
Maximum current (Arms)	42.5			
Rated speed (rpm)	3000			
Maximum speed (rpm)	6000			
Torque coefficient (N·m/Arms)	1.06			
Rotor moment of inertia (kg·cm ²)	Motor without brake			9
	Motor with brake			11.98

Electrical specifications of the motor with brake

Holding torque (N·m)	Supply voltage (VDC)±10%	Rated power (W)	Coil resistance (Ω) (±7%)	Exciting current (A)	Apply time (ms)	Release time (ms)	Backlash (°)
16	24	24	24	1	≤ 120	≤ 60	≤ 1

Allowable load

LF (mm)	Allowable radial load (N)	Allowable axial load (N)
63	1176	392

Dimensions (mm)

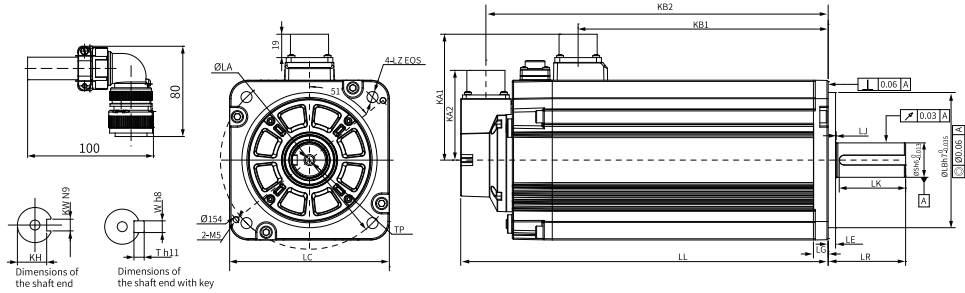

LC	LL	LR	LA	LZ	KA1	KB1	KA2	KB2	LG	LE
130	236 (261)	63±1	145	4-Ø9	102.4	165.5	73	215.5 (240.5)	12	6±0.3
LJ	LB		S	TP	LK	KH	KW	W	T	Weight (kg)
0.5±0.75	Ø110h7 ⁰ _{-0.035}		28	M8 × 20	54	24 ⁰ _{-0.2}	8	8	7	13.2 (15.1)

3.5.13 MS1H2-50C30CB-A33*R-INT

Motor specifications			Torque-Speed characteristics			
Flange size (mm)	130		<p>— A Continuous duty zone — B Intermittent duty zone</p>			
Inertia, capacity	Low inertia, medium capacity					
Rated power (kW)	5.0					
Voltage (V)	220					
Rated torque (N·m)	15.8					
Maximum torque (N·m)	39.5					
Rated current (Arms)	22					
Maximum current (Arms)	67.5					
Rated speed (rpm)	3000					
Maximum speed (rpm)	6000					
Torque coefficient (N·m/Arms)	0.81		<th colspan="2">Heatsink-based derating curve</th>		Heatsink-based derating curve	
Rotor moment of inertia (kg·cm ²)	Motor without brake	11.6				
	Motor with brake	14.58				

Electrical specifications of the motor with brake

Holding torque (N·m)	Supply voltage (VDC)±10%	Rated power (W)	Coil resistance (Ω) (±7%)	Exciting current (A)	Apply time (ms)	Release time (ms)	Backlash (°)
16	24	24	24	1	≤ 120	≤ 60	≤ 1

Allowable load

LF (mm)	Allowable radial load (N)	Allowable axial load (N)
63	1176	392

Dimensions (mm)

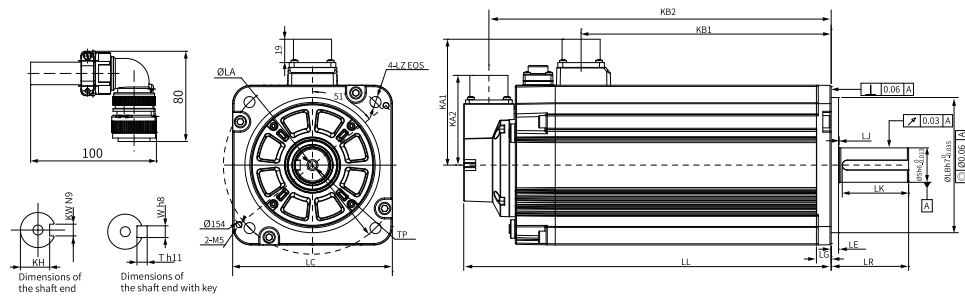

LC	LL	LR	LA	LZ	KA1	KB1	KA2	KB2	LG	LE
130	274 (299)	63±1	145	4-Ø9	102.4	203.5	73	253.5 (278.5)	12	6±0.3
LJ	LB		S	TP	LK	KH	KW	W	T	Weight (kg)
0.5±0.75	Ø110h7 ⁰ _{-0.035}		28	M8 × 20	54	24 ⁰ _{-0.2}	8	8	7	16.35 (18.25)

3.5.14 MS1H2-50C30CD-A33*R-INT

Motor specifications			Torque-Speed characteristics	
Flange size (mm)	130			
Inertia, capacity	Low inertia, medium capacity			
Rated power (kW)	5.0			
Voltage (V)	380			
Rated torque (N·m)	15.8			
Maximum torque (N·m)	47.4			
Rated current (Arms)	17			
Maximum current (Arms)	52.5			
Rated speed (rpm)	3000			
Maximum speed (rpm)	6000			
Torque coefficient (N·m/Arms)	1.04			
Rotor moment of inertia (kg·cm ²)	Motor without brake	11.6		
	Motor with brake	14.58		

Electrical specifications of the motor with brake

Holding torque (N·m)	Supply voltage (VDC)±10%	Rated power (W)	Coil resistance (Ω) (±7%)	Exciting current (A)	Apply time (ms)	Release time (ms)	Backlash (°)
16	24	24	24	1	≤ 120	≤ 60	≤ 1

Allowable load

LF (mm)	Allowable radial load (N)	Allowable axial load (N)
63	1176	392

Dimensions (mm)

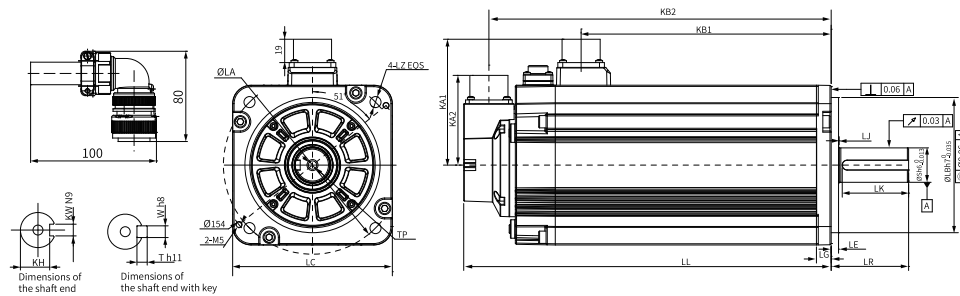

LC	LL	LR	LA	LZ	KA1	KB1	KA2	KB2	LG	LE
130	274 (299)	63±1	145	4-Ø9	102.4	203.5	73	253.5 (278.5)	12	6±0.3
LJ	LB	S	TP	LK	KH	KW	W	T	Weight (kg)	
0.5±0.75	Ø110h7 ⁰ _{-0.035}	28	M8 × 20	54	24 ⁰ _{-0.2}	8	8	7	16.35 (18.25)	

3.6 Motors with Medium Inertia and Medium Capacity (MS1H3)

3.6.1 MS1H3-85B15CB-A33*R-INT

Motor specifications		Torque-Speed characteristics		
Flange size (mm)	130			
Inertia, capacity	Medium inertia, medium capacity			
Rated power (kW)	0.85			
Voltage (V)	220			
Rated torque (N·m)	5.39			
Maximum torque (N·m)	13.5			
Rated current (Arms)	6.6			
Maximum current (Arms)	17.2			
Rated speed (rpm)	1500			
Maximum speed (rpm)	4500			
Torque coefficient (N·m/Arms)	0.93			
Rotor moment of inertia (kg·cm ²)	Motor without brake			13.56
	Motor with brake			15.8

Electrical specifications of the motor with brake

Holding torque (N·m)	Supply voltage (VDC) ±10%	Rated power (W)	Coil resistance (Ω) (±7%)	Exciting current (A)	Apply time (ms)	Release time (ms)	Backlash (°)
16	24	24	24	1	≤ 120	≤ 60	≤ 1

Allowable load

LF (mm)	Allowable radial load (N)	Allowable axial load (N)
55	686	196

Dimensions (mm)

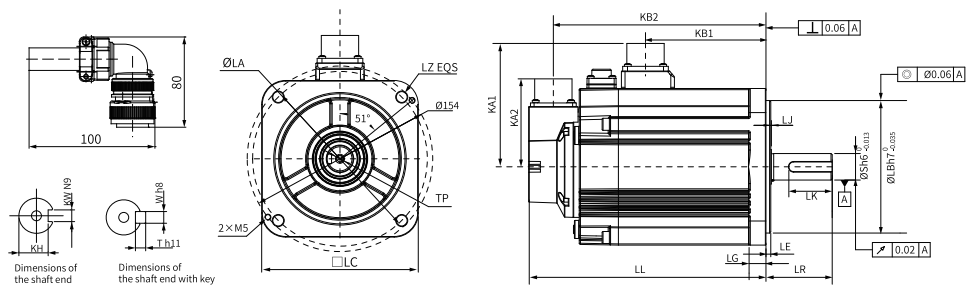

LC	LL	LR	LA	LZ	KA1	KB1	KA2	KB2	LG	LE
130	142 (167)	55 ± 1	145	4-Ø9	103	70	73	121.5 (146.5)	14	4
LJ	LB		S	TP	LK	KH	KW	W	T	Weight (kg)
0.5 ± 0.75	$\phi 110h7^0_{-0.035}$		22	M6 × 20	36	18 ⁰ -0.2	8	8	7	5.8 (7.7)

3.6.2 MS1H3-85B15CD-A33*R-INT

Motor specifications			Torque-Speed characteristics	
Flange size (mm)	130			
Inertia, capacity	Medium inertia, medium capacity			
Rated power (kW)	0.85			
Voltage (V)	380			
Rated torque (N·m)	5.39			
Maximum torque (N·m)	13.5			
Rated current (Arms)	3.5			
Maximum current (Arms)	8.5			
Rated speed (rpm)	1500			
Maximum speed (rpm)	4500			
Torque coefficient (N·m/Arms)	1.84			
Rotor moment of inertia (kg·cm ²)	Motor without brake	13.56		
	Motor with brake	15.8		

Electrical specifications of the motor with brake

Holding torque (N·m)	Supply voltage (VDC)±10%	Rated power (W)	Coil resistance (Ω) (±7%)	Exciting current (A)	Apply time (ms)	Release time (ms)	Backlash (°)
16	24	24	24	1	≤ 120	≤ 60	≤ 1

Allowable load

LF (mm)	Allowable radial load (N)	Allowable axial load (N)
55	686	196

Dimensions (mm)

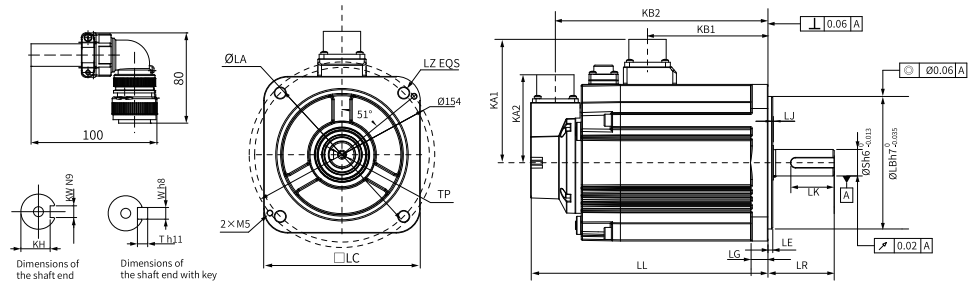

LC	LL	LR	LA	LZ	KA1	KB1	KA2	KB2	LG	LE
130	142 (167)	55±1	145	4-Ø9	103	70	73	121.5 (146.5)	14	4
LJ	LB	S	TP	LK	KH	KW	W	T	Weight (kg)	
0.5±0.75	Ø110h7 ⁰ _{-0.035}	22	M6 × 20	36	18 ⁰ _{-0.2}	8	8	7	5.8 (7.7)	

3.6.3 MS1H3-13C15CB-A33*R-INT

Motor specifications			Torque-Speed characteristics	
Flange size (mm)	130			
Inertia, capacity	Medium inertia, medium capacity			
Rated power (kW)	1.3			
Voltage (V)	220			
Rated torque (N·m)	8.34			
Maximum torque (N·m)	20.85			
Rated current (Arms)	10.5			
Maximum current (Arms)	27.3			
Rated speed (rpm)	1500			
Maximum speed (rpm)	4500			
Torque coefficient (N·m/Arms)	0.89			
Rotor moment of inertia (kg·cm ²)	Motor without brake	19.25		
	Motor with brake	21.5		

Electrical specifications of the motor with brake

Holding torque (N·m)	Supply voltage (VDC) ±10%	Rated power (W)	Coil resistance (Ω) (±7%)	Exciting current (A)	Apply time (ms)	Release time (ms)	Backlash (°)
16	24	24	24	1	≤ 120	≤ 60	≤ 1

Allowable load

LF (mm)	Allowable radial load (N)	Allowable axial load (N)
55	686	196

Dimensions (mm)

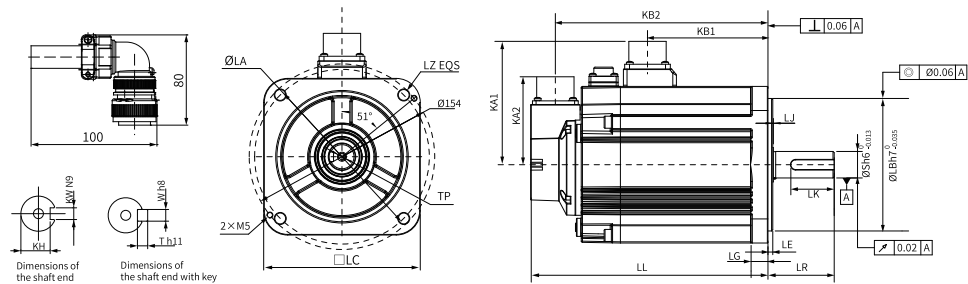

LC	LL	LR	LA	LZ	KA1	KB1	KA2	KB2	LG	LE
130	157 (182)	55±1	145	4-Ø9	103	85	73	136.5 (161.5)	14	4
LJ	LB	S	TP	LK	KH	KW	W	T	Weight (kg)	
0.5±0.75	Ø110h7 ⁰ _{-0.035}	22	M6 × 20	36	18 ⁰ _{-0.2}	8	8	7	7.1 (8.9)	

3.6.4 MS1H3-13C15CD-A33*R-INT

Motor specifications			Torque-Speed characteristics	
Flange size (mm)	130			
Inertia, capacity	Medium inertia, medium capacity			
Rated power (kW)	1.3			
Voltage (V)	380			
Rated torque (N·m)	8.34			
Maximum torque (N·m)	20.85			
Rated current (Arms)	5.1			
Maximum current (Arms)	12.6			
Rated speed (rpm)	1500			
Maximum speed (rpm)	4500			
Torque coefficient (N·m/Arms)	1.85			
Rotor moment of inertia (kg·cm ²)	Motor without brake	19.25		
	Motor with brake	21.5		

Electrical specifications of the motor with brake

Holding torque (N·m)	Supply voltage (VDC)±10%	Rated power (W)	Coil resistance (Ω) (±7%)	Exciting current (A)	Apply time (ms)	Release time (ms)	Backlash (°)
16	24	24	24	1	≤ 120	≤ 60	≤ 1

Allowable load

LF (mm)	Allowable radial load (N)	Allowable axial load (N)
55	686	196

Dimensions (mm)

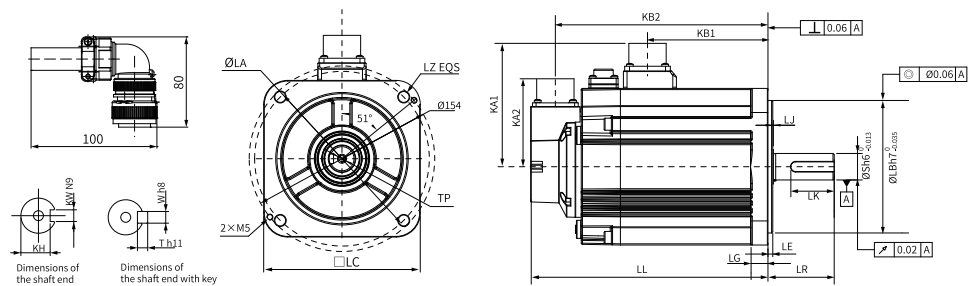

LC	LL	LR	LA	LZ	KA1	KB1	KA2	KB2	LG	LE
130	157 (182)	55±1	145	4-Ø9	103	85	73	136.5 (161.5)	14	4
LJ	LB	S	TP	LK	KH	KW	W	T	Weight (kg)	
0.5±0.75	Ø110h7 ⁰ _{-0.035}	22	M6 × 20	36	18 ⁰ _{-0.2}	8	8	7	7.1 (8.9)	

3.6.5 MS1H3-18C15CB-A33*R-INT

Motor specifications			Torque-Speed characteristics	
Flange size (mm)	130			
Inertia, capacity	Medium inertia, medium capacity			
Rated power (kW)	1.8			
Voltage (V)	220			
Rated torque (N·m)	11.5			
Maximum torque (N·m)	28.75			
Rated current (Arms)	11.9			
Maximum current (Arms)	32.2			
Rated speed (rpm)	1500			
Maximum speed (rpm)	4500			
Torque coefficient (N·m/Arms)	1.05			
Rotor moment of inertia (kg·cm ²)	Motor without brake	24.9		
	Motor with brake	27.2		

Electrical specifications of the motor with brake

Holding torque (N·m)	Supply voltage (VDC)±10%	Rated power (W)	Coil resistance (Ω) (±7%)	Exciting current (A)	Apply time (ms)	Release time (ms)	Backlash (°)
16	24	24	24	1	≤ 120	≤ 60	≤ 1

Allowable load

LF (mm)	Allowable radial load (N)	Allowable axial load (N)
55	686	196

Dimensions (mm)

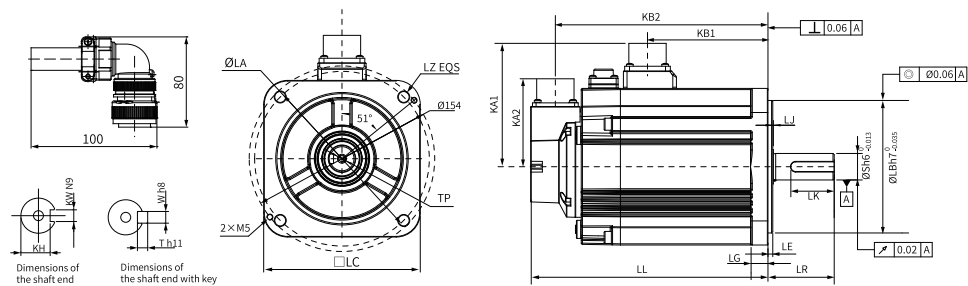

LC	LL	LR	LA	LZ	KA1	KB1	KA2	KB2	LG	LE
130	172 (197)	55±1	145	4-Ø9	103	100	73	151.5 (176.5)	14	4
LJ	LB	S	TP	LK	KH	KW	W	T	Weight (kg)	
0.5±0.75	Ø110h7 ⁰ _{-0.035}	22	M6 × 20	36	18 ⁰ _{-0.2}	8	8	7	8.5 (10.3)	

3.6.6 MS1H3-18C15CD-A33*R-INT

Motor specifications			Torque-Speed characteristics	
Flange size (mm)	130			
Inertia, capacity	Medium inertia, medium capacity			
Rated power (kW)	1.8			
Voltage (V)	380			
Rated torque (N·m)	11.5			
Maximum torque (N·m)	28.75			
Rated current (Arms)	6.75			
Maximum current (Arms)	17.7			
Rated speed (rpm)	1500			
Maximum speed (rpm)	4500			
Torque coefficient (N·m/Arms)	1.87			
Rotor moment of inertia (kg·cm ²)	Motor without brake	24.9		
	Motor with brake	27.2		

Electrical specifications of the motor with brake

Holding torque (N·m)	Supply voltage (VDC)±10%	Rated power (W)	Coil resistance (Ω) (±7%)	Exciting current (A)	Apply time (ms)	Release time (ms)	Backlash (°)
16	24	24	24	1	≤ 120	≤ 60	≤ 1

Allowable load

LF (mm)	Allowable radial load (N)	Allowable axial load (N)
55	686	196

Dimensions (mm)

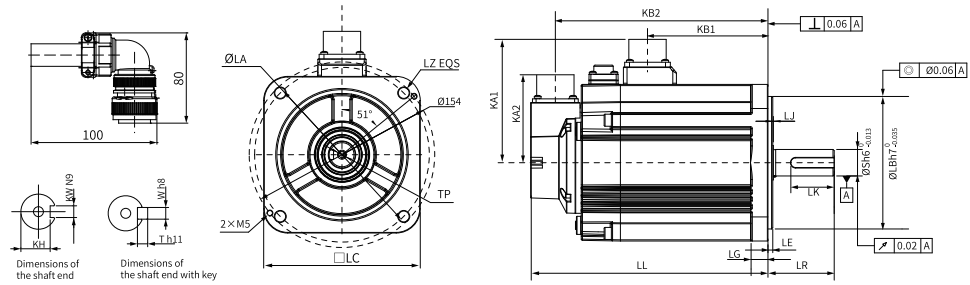

LC	LL	LR	LA	LZ	KA1	KB1	KA2	KB2	LG	LE
130	172 (197)	55±1	145	4-Ø9	103	100	73	151.5 (176.5)	14	4
LJ	LB	S	TP	LK	KH	KW	W	T	Weight (kg)	
0.5±0.75	Ø110h7 ⁰ _{-0.035}	22	M6 × 20	36	18 ⁰ _{-0.2}	8	8	7	8.5 (10.3)	

3.6.7 MS1H3-29C15CB-A33*R-INT

Motor specifications			Torque-Speed characteristics	
Flange size (mm)	180		<p>— A Continuous duty zone — B Intermittent duty zone</p>	
Inertia, capacity	Medium inertia, medium capacity			
Rated power (kW)	2.9			
Voltage (V)	220			
Rated torque (N·m)	18.6			
Maximum torque (N·m)	46.5			
Rated current (Arms)	18			
Maximum current (Arms)	52.5			
Rated speed (rpm)	1500			
Maximum speed (rpm)	4500			
Torque coefficient (N·m/Arms)	1.16			
Rotor moment of inertia (kg·cm ²)	Motor without brake	44.7		
	Motor with brake	52.35		

Electrical specifications of the motor with brake

Holding torque (N·m)	Supply voltage (VDC) ±10%	Rated power (W)	Coil resistance (Ω) (±7%)	Exciting current (A)	Apply time (ms)	Release time (ms)	Backlash (°)
50	24	31	18.58	1.29	≤ 200	≤ 100	≤ 1

Allowable load

LF (mm)	Allowable radial load (N)	Allowable axial load (N)
79	1470	490

Dimensions (mm)

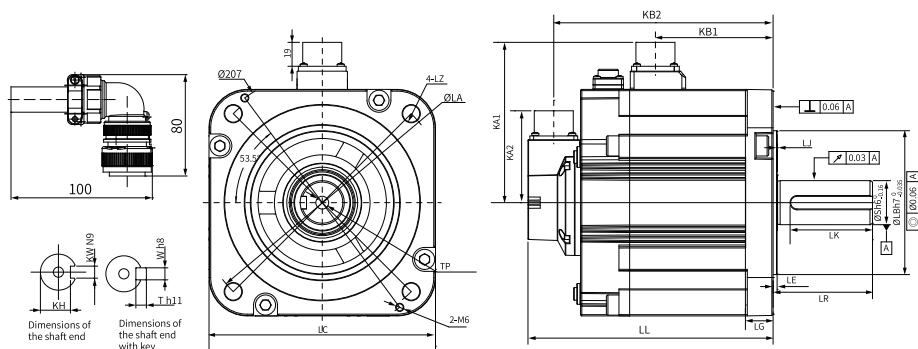

LC	LL	LR	LA	LZ	KA1	KB1	KA2	KB2	LG	LE
180	161 (194.8)	79 ± 1	200	4-Ø13.5	127.4	93.5	73	140.5 (174.3)	22	3.2 ± 0.3
LJ	LB	S	TP	LK	KH	KW	W	T	Weight (kg)	
0.5 ± 0.75	Ø114.3h7 ⁰ _{-0.035}	35	M12x25	65	30 ⁰ _{-0.2}	10	10	8	13.8 (17.9)	

3.6.8 MS1H3-29C15CD-A33*R-INT

Motor specifications			Torque-Speed characteristics	
Flange size (mm)	180		<p>— A Continuous duty zone — B Intermittent duty zone</p>	
Inertia, capacity	Medium inertia, medium capacity			
Rated power (kW)	2.9			
Voltage (V)	380			
Rated torque (N·m)	18.6			
Maximum torque (N·m)	46.5			
Rated current (Arms)	10.5			
Maximum current (Arms)	29.75			
Rated speed (rpm)	1500			
Maximum speed (rpm)	4500			
Torque coefficient (N·m/Arms)	1.94		<p>Max. allowable load rate (%)</p> <p>Heatsink dimensions (mm)</p>	
Rotor moment of inertia (kg·cm ²)	Motor without brake	44.7		
	Motor with brake	52.35		

Electrical specifications of the motor with brake

Holding torque (N·m)	Supply voltage (VDC)±10%	Rated power (W)	Coil resistance (Ω) (±7%)	Exciting current (A)	Apply time (ms)	Release time (ms)	Backlash (°)
50	24	31	18.58	1.29	≤ 200	≤ 100	≤ 1

Allowable load

LF (mm)	Allowable radial load (N)	Allowable axial load (N)
79	1470	490

Dimensions (mm)

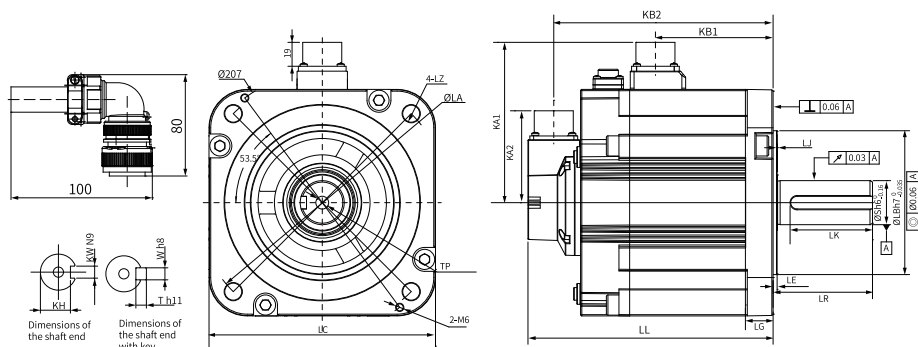

LC	LL	LR	LA	LZ	KA1	KB1	KA2	KB2	LG	LE
180	161 (194.8)	79±1	200	4-Ø13.5	127.4	93.5	73	140.5 (174.3)	22	3.2±0.3
LJ	LB	S	TP	LK	KH	KW	W	T	Weight (kg)	
0.5±0.75	Ø114.3h7 ⁰ _{-0.035}	35	M12x25	65	30 ⁰ _{-0.2}	10	10	8	13.8 (17.9)	

3.6.9 MS1H3-44C15CB-A33*R-INT

Motor specifications			Torque-Speed characteristics	
Flange size (mm)	180		<p>— A Continuous duty zone — B Intermittent duty zone</p>	
Inertia, capacity	Medium inertia, medium capacity			
Rated power (kW)	4.4			
Voltage (V)	220			
Rated torque (N·m)	28.4			
Maximum torque (N·m)	71.1			
Rated current (Arms)	25.5			
Maximum current (Arms)	67			
Rated speed (rpm)	1500			
Maximum speed (rpm)	4500			
Torque coefficient (N·m/Arms)	1.25			
Rotor moment of inertia (kg·cm ²)	Motor without brake	64.9		
	Motor with brake	72.55		

Electrical specifications of the motor with brake

Holding torque (N·m)	Supply voltage (VDC) ±10%	Rated power (W)	Coil resistance (Ω) (±7%)	Exciting current (A)	Apply time (ms)	Release time (ms)	Backlash (°)
50	24	31	18.58	1.29	≤ 200	≤ 100	≤ 1

Allowable load

LF (mm)	Allowable radial load (N)	Allowable axial load (N)
79	1470	490

Dimensions (mm)

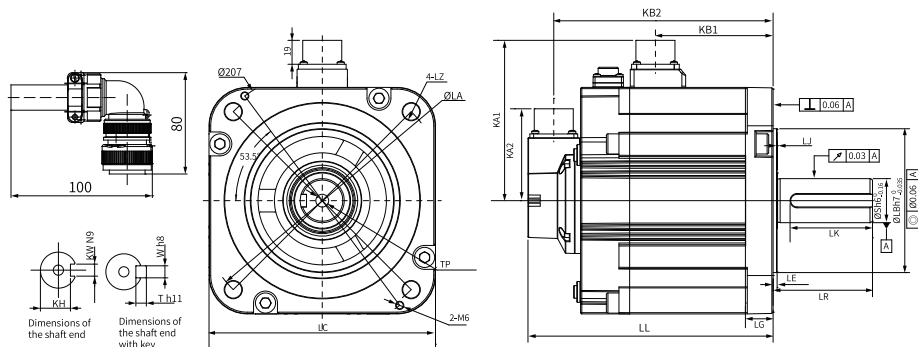

LC	LL	LR	LA	LZ	KA1	KB1	KA2	KB2	LG	LE
180	184.5 (218.3)	79 ± 1	200	4-Ø13.5	127.4	117	73	164 (197.8)	22	3.2 ± 0.3
LJ	LB	S	TP	LK	KH	KW	W	T	Weight (kg)	
0.5 ± 0.75	Ø114.3h7 ⁰ _{-0.035}	35	M12x25	65	30 ⁰ _{-0.2}	10	10	8	17.4 (21.9)	

3.6.10 MS1H3-44C15CD-A33*R-INT

Motor specifications			Torque-Speed characteristics	
Flange size (mm)	180			
Inertia, capacity	Medium inertia, medium capacity			
Rated power (kW)	4.4			
Voltage (V)	380			
Rated torque (N·m)	28.4			
Maximum torque (N·m)	71.1			
Rated current (Arms)	16			
Maximum current (Arms)	42			
Rated speed (rpm)	1500			
Maximum speed (rpm)	4500			
Torque coefficient (N·m/Arms)	1.96			
Rotor moment of inertia (kg·cm ²)	Motor without brake	64.9		
	Motor with brake	72.55		

Electrical specifications of the motor with brake

Holding torque (N·m)	Supply voltage (VDC)±10%	Rated power (W)	Coil resistance (Ω) (±7%)	Exciting current (A)	Apply time (ms)	Release time (ms)	Backlash (°)
50	24	31	18.58	1.29	≤ 200	≤ 100	≤ 1

Allowable load

LF (mm)	Allowable radial load (N)	Allowable axial load (N)
79	1470	490

Dimensions (mm)

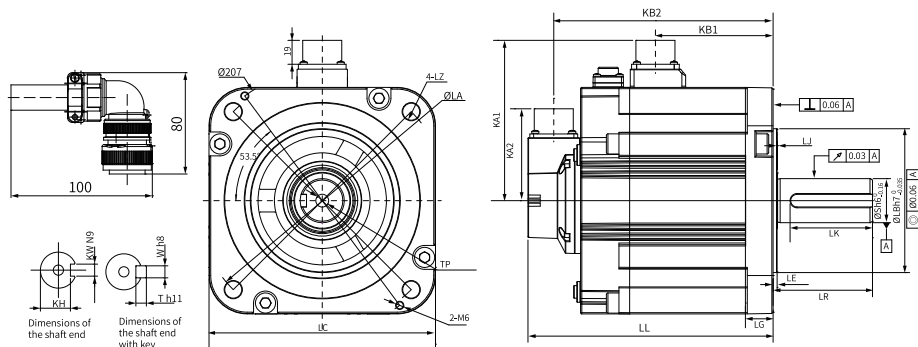

LC	LL	LR	LA	LZ	KA1	KB1	KA2	KB2	LG	LE
180	184.5 (218.3)	79±1	200	4-Ø13.5	127.4	117	73	164 (197.8)	22	3.2±0.3
LJ	LB	S	TP	LK	KH	KW	W	T	Weight (kg)	
0.5±0.75	Ø114.3h7 ⁰ _{-0.035}	35	M12x25	65	30 ⁰ _{-0.2}	10	10	8	17.4 (21.6)	

3.6.11 MS1H3-55C15CD-A33*R-INT

Motor specifications			Torque-Speed characteristics	
Flange size (mm)	180			
Inertia, capacity	Medium inertia, medium capacity			
Rated power (kW)	5.5			
Voltage (V)	380			
Rated torque (N·m)	35			
Maximum torque (N·m)	87.6			
Rated current (Arms)	20.7			
Maximum current (Arms)	52			
Rated speed (rpm)	1500			
Maximum speed (rpm)	4500			
Torque coefficient (N·m/Arms)	1.92			
Rotor moment of inertia (kg·cm ²)	Motor without brake	86.9		
	Motor with brake	94.55		

Electrical specifications of the motor with brake

Holding torque (N·m)	Supply voltage (VDC)±10%	Rated power (W)	Coil resistance (Ω) (±7%)	Exciting current (A)	Apply time (ms)	Release time (ms)	Backlash (°)
50	24	31	18.58	1.29	≤ 200	≤ 100	≤ 1

Allowable load

LF (mm)	Allowable radial load (N)	Allowable axial load (N)
113	1764	588

Dimensions (mm)

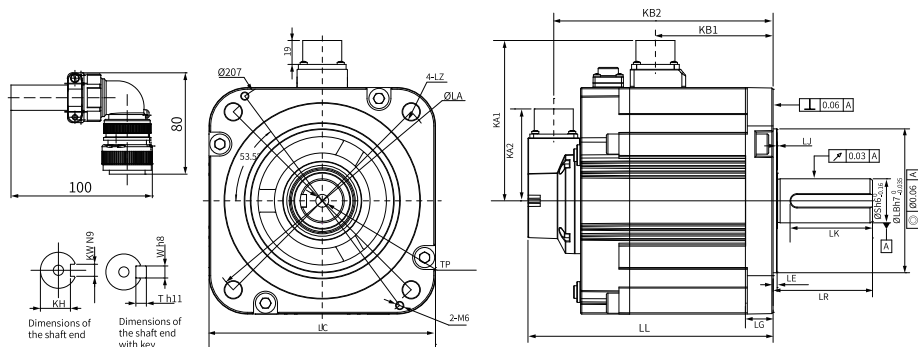

LC	LL	LR	LA	LZ	KA1	KB1	KA2	KB2	LG	LE
180	208 (241.8)	113±1	200	4-Ø13.5	127.4	140.5	73	187.5 (221.3)	22	3.2±0.3
LJ	LB	S	TP	LK	KH	KW	W	T	Weight (kg)	
0.5±0.75	Ø114.3h7 ⁰ _{-0.035}	42	M16x32	97	37 ⁰ _{-0.2}	12	12	8	21.7 (25.9)	

3.6.12 MS1H3-75C15CD-A33*R-INT

Motor specifications			Torque-Speed characteristics	
Flange size (mm)	180			
Inertia, capacity	Medium inertia, medium capacity			
Rated power (kW)	7.5			
Voltage (V)	380			
Rated torque (N·m)	48			
Maximum torque (N·m)	119			
Rated current (Arms)	25			
Maximum current (Arms)	65			
Rated speed (rpm)	1500			
Maximum speed (rpm)	4500			
Torque coefficient (N·m/Arms)	2.13			
Rotor moment of inertia (kg·cm ²)	Motor without brake	127.5		
	Motor with brake	135.15		

Electrical specifications of the motor with brake

Holding torque (N·m)	Supply voltage (VDC)±10%	Rated power (W)	Coil resistance (Ω) (±7%)	Exciting current (A)	Apply time (ms)	Release time (ms)	Backlash (°)
50	24	31	18.58	1.29	≤ 200	≤ 100	≤ 1

Allowable load

LF (mm)	Allowable radial load (N)	Allowable axial load (N)
113	1764	588

Dimensions (mm)

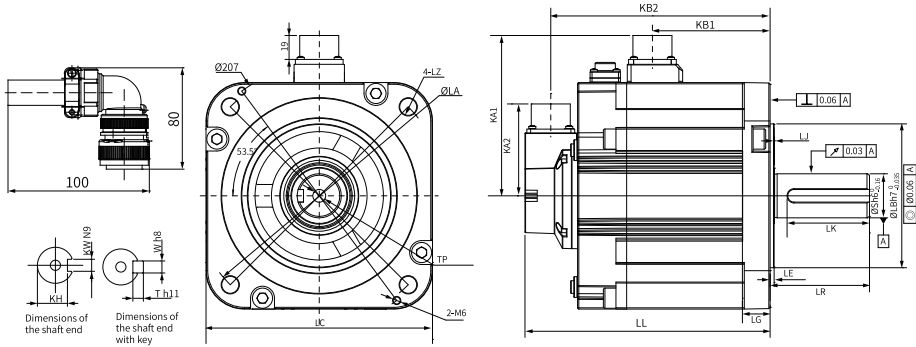

LC	LL	LR	LA	LZ	KA1	KB1	KA2	KB2	LG	LE
180	255 (288.8)	113±1	200	4-Ø13.5	127.4	187.5	73	234.5 (234.5)	22	3.2±0.3
LJ	LB	S	TP	LK	KH	KW	W	T	Weight (kg)	
0.5±0.75	Ø114.3h7 ⁰ _{-0.035}	42	M16x32	97	37 ⁰ _{-0.2}	12	12	8	29 (33.2)	

3.7 Motors with Medium Inertia and Small Capacity (MS1H4)

3.7.1 MS1H4-10B30CB-A33*Z-INT

Motor specifications			Torque-Speed characteristics	
Flange size (mm)	40			
Inertia, capacity	Low inertia, small capacity			
Rated output (kW)	0.1			
Voltage (V)	220			
Rated torque (N·m)	0.32			
Maximum torque (N·m)	1.12			
Rated current (Arms)	1.3			
Maximum current (Arms)	4.70			
Rated speed (rpm)	3000			
Maximum speed (rpm)	7000			
Torque coefficient (N·m/Arms)	0.26			
Rotor moment of inertia (kg·cm ²)	Motor without brake	0.102		
	Motor with brake	0.104		

Note[1:]For torque-speed characteristics of the A3/T3 encoder, see MS1-Z Series Servo Motor Selection Guide.

Electrical specifications of the motor with brake

Holding torque (N·m)	Supply voltage (VDC)±10%	Rated power (W)	Coil resistance (Ω) (±7%)	Exciting current (A)	Apply time (ms)	Release time (ms)	Backlash (°)
0.32	24	6.1	94.4	0.25	≤ 40	≤ 20	≤ 1.5

Allowable load

LF (mm)	Allowable radial Load (N)	Allowable axial Load (N)
20	78	54

Dimensions (mm)

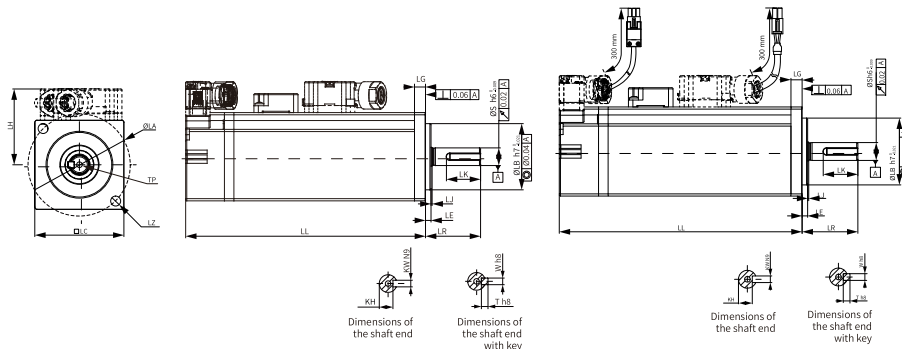

LL	LC	LR	LA	LZ	LH	LG	LE	LJ
91 (121.5)	40	25±0.5	46	2-Ø4.5	34.3	5	2.5±0.5	0.5±0.35
S	LB	TP	LK	KH	kW	W	T	Weight (kg)
8	Ø30h7 ⁰ -0.021	M3x6	15.5	6.2 ⁰ -0.1	3	3	3	0.45 (0.64)

3.7.2 MS1H4-20B30CB-A33*R-INT

Motor specifications			Torque-Speed characteristics
Flange size (mm)	60		
Inertia, capacity	Medium inertia, low capacity		
Rated power (kW)	0.2		
Voltage (V)	220		
Rated torque (N·m)	0.64		
Maximum torque (N·m)	2.24		
Rated current (Arms)	1.3		Heatsink-based derating curve
Maximum current (Arms)	5.3		
Rated speed (rpm)	3000		
Maximum speed (rpm)	7000		
Torque coefficient (N·m/Arms)	0.46		
Rotor moment of inertia (kg·cm ²)	Motor without brake	0.22	
	Motor with brake	0.23	

Electrical specifications of the motor with brake

Holding torque (N·m)	Supply voltage (VDC)±10%	Rated power (W)	Coil resistance (Ω) (±7%)	Exciting current (A)	Apply time (ms)	Release time (ms)	Backlash (°)
1.5	24	7.6	75.79	0.32	≤ 60	≤ 20	≤ 1.5

Allowable load

LF (mm)	Allowable radial load (N)	Allowable axial load (N)
25	245	74

Dimensions (mm)

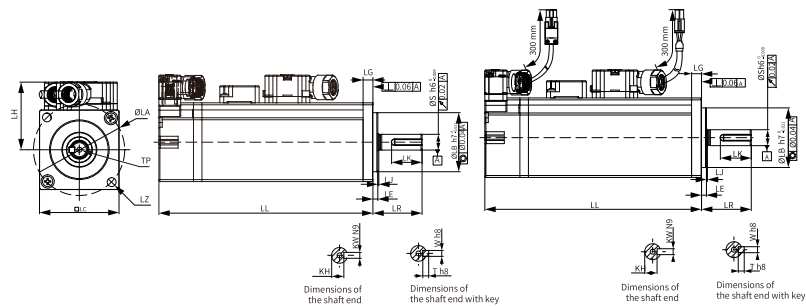

LC	LL	LR	LA	LZ	LH	LG	LE	LJ
60	73.5 (101.1)	30±0.5	70	4-Ø 5.5	44	8.0	3±0.5	0.5±0.35
LB	S	TP	LK	KH	KW	W	T	Weight (kg)
Ø50h7 ⁰ -0.025	14	M5x8	16.5	11 ⁰ -0.1	5	5	5	0.78 (1.16)

3.7.3 MS1H4-40B30CB-A33*R-INT

Motor specifications			Torque-Speed characteristics	
Flange size (mm)	60			
Inertia, capacity	Medium inertia, low capacity			
Rated power (kW)	0.4			
Voltage (V)	220			
Rated torque (N·m)	1.27			
Maximum torque (N·m)	4.45			
Rated current (Arms)	2.4		Heatsink-based derating curve	
Maximum current (Arms)	9.2			
Rated speed (rpm)	3000			
Maximum speed (rpm)	7000			
Torque coefficient (N·m/Arms)	0.53			
Rotor moment of inertia (kg·cm ²)	Motor without brake	0.43		
	Motor with brake	0.44		

Electrical specifications of the motor with brake

Holding torque (N·m)	Supply voltage (VDC) ±10%	Rated power (W)	Coil resistance (Ω) (±7%)	Exciting current (A)	Apply time (ms)	Release time (ms)	Backlash (°)
1.5	24	7.6	75.79	0.32	≤ 60	≤ 20	≤ 1.5

Allowable load

LF (mm)	Allowable radial load (N)	Allowable axial load (N)
25	245	74

Dimensions (mm)

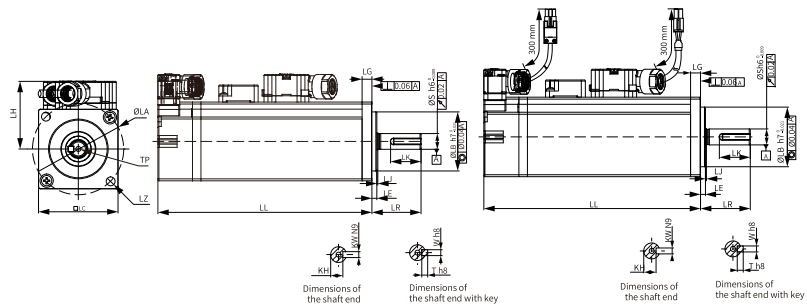

LC	LL	LR	LA	LZ	LH	LG	LE	LJ
60	92 (119.8)	30 ± 0.5	70	4- Ø 5.5	44	8.0	3 ± 0.5	0.5±0.35
LB	S	TP	LK	KH	KW	W	T	Weight (kg)
Ø50h7 ⁰ -0.025	14	M5x8	16.5	11 ⁰ -0.1	5	5	5	1.11 (1.48)

3.7.4 MS1H4-55B30CB-A33*R-INT

Motor specifications		Torque-Speed characteristics	
Flange size (mm)	80		
Inertia, capacity	Medium inertia, low capacity		
Rated power (kW)	0.55		
Voltage (V)	220		
Rated torque (N·m)	1.75		
Maximum torque (N·m)	6.13		
Rated current (Arms)	3.3		
Maximum current (Arms)	13.2		
Rated speed (rpm)	3000		
Maximum speed (rpm)	7000		
Torque coefficient (N·m/Arms)	0.49		
Motor without brake	1.12		
Motor with brake	-		

Allowable load

LF (mm)	Allowable radial load (N)	Allowable axial load (N)
35	392	147

Dimensions (mm)

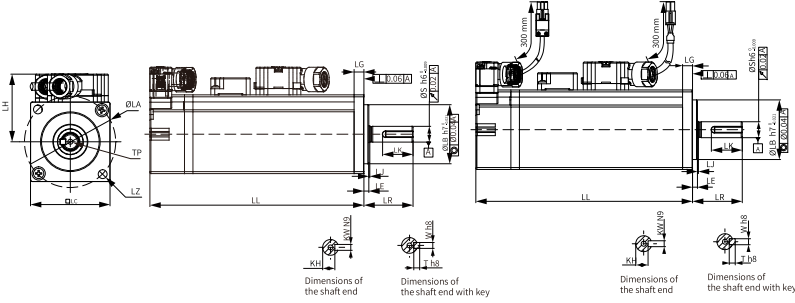

LC	LL	LR	LA	LZ	LH	LG	LE	LJ
80	96.7	25±0.5	90	4-Ø7	54	7.5	3±0.5	0.5±0.35
LB	S	TP	LK	KH	KW	W	T	Weight (kg)
Ø70h7 ⁰ -0.03	19	M6 x 20	26	15.5 ⁰ -0.1	6	6	6	1.85

3.7.5 MS1H4-75B30CB-A33*R-INT

Motor specifications			Torque-Speed characteristics	
Flange size (mm)	80			
Inertia, capacity	Medium inertia, low capacity			
Rated power (kW)	0.75			
Voltage (V)	220			
Rated torque (N·m)	2.39			
Maximum torque (N·m)	8.37			
Rated current (Arms)	4.4			
Maximum current (Arms)	16.9			
Rated speed (rpm)	3000			
Maximum speed (rpm)	7000			
Torque coefficient (N·m/Arms)	0.58			
Rotor moment of inertia (kg·cm ²)	Motor without brake	1.46		
	Motor with brake	1.51		

Electrical specifications of the motor with brake

Holding torque (N·m)	Supply voltage (VDC)±10%	Rated power (W)	Coil resistance (Ω) (±7%)	Exciting current (A)	Apply time (ms)	Release time (ms)	Backlash (°)
3.2	24	10	57.6	0.42	≤ 60	≤ 40	≤ 1

Allowable load

LF (mm)	Allowable radial load (N)	Allowable axial load (N)
35	392	147

Dimensions (mm)

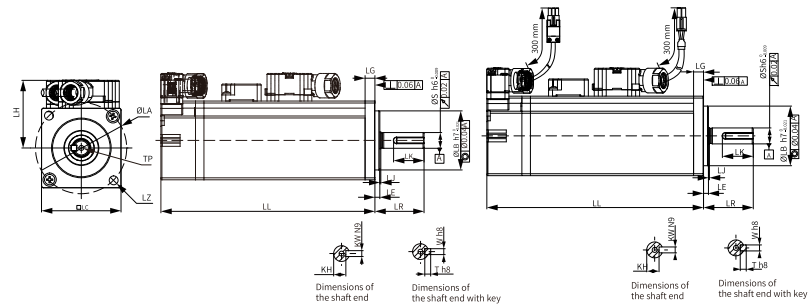

LC	LL	LR	LA	LZ	LH	LG	LE	LJ
80	107.3 (141.5)	25±0.5	90	4- Ø 7	54	7.5	3 ± 0.5	0.5±0.35
LB	S	TP	LK	KH	KW	W	T	Weight (kg)
Ø 70h7 ⁰ _{-0.03}	19	M6 × 20	26	15.5 ⁰ _{-0.1}	6	6	6	2.18 (2.82)

3.7.6 MS1H4-10C30CB-A33*R-INT

Motor specifications			Torque-Speed characteristics			
Flange size (mm)	80					
Inertia, capacity	Medium inertia, low capacity					
Rated power (kW)	1.0					
Voltage (V)	220					
Rated torque (N·m)	3.18					
Maximum torque (N·m)	11.13					
Rated current (Arms)	6.5					
Maximum current (Arms)	24					
Rated speed (rpm)	3000					
Maximum speed (rpm)	7000					
Torque coefficient (N·m/Arms)	0.46		<th colspan="2">Heatsink-based derating curve</th>		Heatsink-based derating curve	
Rotor moment of inertia (kg·cm ²)	Motor without brake	1.87				
	Motor with brake	1.97				
Motor specifications						
Motor specifications						

Electrical specifications of the motor with brake

Holding torque (N·m)	Supply voltage (VDC)±10%	Rated power (W)	Coil resistance (Ω) (±7%)	Exciting current (A)	Apply time (ms)	Release time (ms)	Backlash (°)
3.2	24	10	57.6	0.42	≤ 60	≤ 40	≤ 1

Allowable load

LF (mm)	Allowable radial load (N)	Allowable axial load (N)
35	392	147

Dimensions (mm)

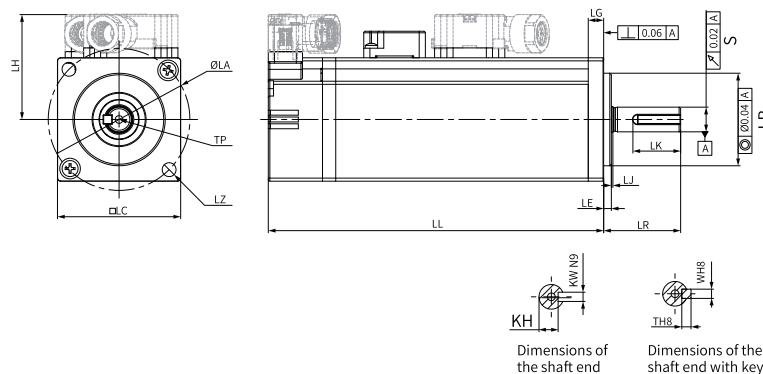

LC	LL	LR	LA	LZ	LH	LG	LE	LJ
80	118.7 (153.2)	25±0.5	90	4- Ø7	54	7.5	3 ± 0.5	0.5±0.35
LB	S	TP	LK	KH	KW	W	T	Weight (kg)
Ø70h7 ⁰ _{-0.03}	19	M6 x 20	26	15.5 ⁰ _{-0.1}	6	6	6	2.55 (2.9)

4 Options

4.1 Option List

Type	Name	Installation Position	Applicable Drive Model	Function
Peripheral Electrical Components	Fuse and circuit breaker	Input side of the drive	All models	To comply with EN 61800-5-1 and UL61800-5-1 standards, install a fuse/circuit breaker on the input side of the servo drive to prevent accidents caused by short circuit in the internal circuit.
	AC input reactor	Input side of the drive		It is used to eliminate the higher harmonics of the input side effectively and improve the power factor of the input side.
	EMC filter	Input side of the drive		It is used to reduce external conduction and radiation interference of the drive.
	Magnetic ring and ferrite clamp	Output side of the drive		Reduces interferences to the outside and the bearing current.
		Signal cable		Improves the anti-interference performance of signals.

4.2 Applicable Cables

4.2.1 Model Number of Cables

Power cable

S6-L-M 0 0 0 - 3.0 -ZJ - INT
① ②③④ ⑤ ⑥ ⑦

① Cable Type S6-L-B/M: motion control power cable B: with brake M: without brake	③ Cable Size (mm²) 0: frame sizes 25/40/60/80 1: frame sizes 100/130/180 (drive rated current < 13 A) 2: frame size 180 (drive rated current > 13 A)	⑤ Cable Length (m) 3.0: 3 m 5.0: 5 m 10.0: 10 m
② Connector type at drive side 0: U-shaped cable lug 1: Needle-shaped cable lug	④ Connector type at motor side 1: 9-core military-spec connector 2: 6-core military-spec connector 7: SDC-06T series connector (front outgoing)	⑥ Special requirements ZJ: with shield bracket ⑦ Special requirements INT: global version ^[1]

Note

[1]: The material of the global version cables complies with CE and UL certification.

Model number of encoder cables

S6-L-P 1 2 1 - 3.0 - INT
 ① ② ③ ④ ⑤ ⑥

① Cable Type S6-L-P: Motion control encoder cable	③ Encoder 2: Multi-turn absolute	⑤ Cable Length (m) 3.0: 3 m 5.0: 5m 10.0: 10m
② Connector type at drive side 1: USB	④ Connector type at motor side 1: 9-core military-spec connector 4: SDC-06T series connector (front outgoing)	⑥ Special requirements INT: global version ^[1]

Note

[1]: The material of the global version cables complies with CE and UL certification.

Model number of communication cables

S6N-L-T 00 - 3.0
 ① ② ③

① Cable Type S6-L-T: Motion control communication cable S6N-L-T: IS620F Motion Control Encoder Cable (only for servo drive PC communication cable)	② Cable type 00: Servo drive PC communication cable 01: Servo drive network communication cable (CAN&485) 02: Servo drive and PLC communication cable 03: Servo drive termination resistor cable 04: Servo drive network communication cable (EtherCAT)	③ Cable Length (m) 3.0: 3 m 5.0: 5m 10.0: 10m
---	---	---

4.2.2 Cable Type

Fixed cables

Do not bend or move fixed cables during use. Bending or moving fixed cables may damage the cables and lead to a series of cable-related faults such as poor contact. Secure fixed cables through fixed binding. Certain bending radius must be available for the cables to prevent stress.

Flexible cables

Flexible cables can move along with cable carriers without a high risk of abrasion.

Note

- Do not twist or wind the cables in the drag chain.
 - Ensure cables can move freely within the bending radius. Relative movement must be allowed between cables or between cables and the guiding device.
 - Cables in the drag chain can be fixed or bundled through the two unmovable ends of the drag chain.
-

Oil-resistant cables

Oil-resistant cables apply to applications requiring shielded power cables, such as machine tools, cutting fluids, and cutting compounds.

Note

- For motors with terminal box, if the encoder cable is longer than 25 m, S6-C24 cable kit is required. Contact Inovance sales staff for details on the cable length.
 - For motors with flying leads, contact Inovance sales staff for encoder cables longer than 25 m.
-

4.2.3 Cable Selection

Power cable

Motor Model		Cable Model	L Cable Length (mm)	Tolerance (T) (mm)	Illustration
MS1H1/ MS1H4 motor	Power cable for motor without brake	S6-L-M107-3.0-INT	3000	(-30.30)	
		S6-L-M107-5.0-INT	5000	(-30.30)	
		S6-L-M107-10.0-INT	10000	(-30.30)	
		S6-L-M107-3.0-ZJ-INT	3000	(-20.20)	
		S6-L-M107-5.0-ZJ-INT	5000	(-20.20)	
		S6-L-M107-10.0-ZJ-INT	10000	(-20.20)	
	Brake	S6-L-B107-3.0-INT	3000	(-30.30)	
		S6-L-B107-5.0-INT	5000	(-30.30)	
		S6-L-B107-10.0-INT	10000	(-30.30)	
		S6-L-B107-3.0-ZJ-INT	3000	(-20.20)	
		S6-L-B107-5.0-ZJ-INT	5000	(-20.20)	
		S6-L-B107-10.0-ZJ-INT	10000	(-20.20)	
MS1H2 motor rated 3 kW or below/ MS1H3 motor rated 1.8 kW or below	Power cable for motor without brake	S6-L-M111-3.0-INT	3000	(-30.30)	
		S6-L-M111-5.0-INT	5000	(-30.30)	
		S6-L-M111-10.0-INT	10000	(-30.30)	
		S6-L-M111-3.0-ZJ-INT	3000	(-20.20)	
		S6-L-M111-5.0-ZJ-INT	5000	(-20.20)	
		S6-L-M111-10.0-ZJ-INT	10000	(-20.20)	
	Brake	S6-L-B111-3.0-INT	3000	(-30.30)	
		S6-L-B111-5.0-INT	5000	(-30.30)	
		S6-L-B111-10.0-INT	10000	(-30.30)	
		S6-L-B111-3.0-ZJ-INT	3000	(-20.20)	
		S6-L-B111-5.0-ZJ-INT	5000	(-20.20)	
		S6-L-B111-10.0-ZJ-INT	10000	(-20.20)	

Options

Motor Model		Cable Model	L Cable Length (mm)	Tolerance (T) (mm)	Illustration	
MS1H2 motor rated 4 kW/5 kW	Power cable for motor without brake	S6-L-M011-3.0-INT	3000	(-30.30)		
		S6-L-M011-5.0-INT	5000	(-30.30)		
		S6-L-M011-10.0-INT	10000	(-30.30)		
		S6-L-M011-3.0-ZJ-INT	3000	(-20.20)		
		S6-L-M011-5.0-ZJ-INT	5000	(-20.20)		
		S6-L-M011-10.0-ZJ-INT	10000	(-20.20)		
	Brake	S6-L-B011-3.0-INT	3000	(-30.30)		
		S6-L-B011-5.0-INT	5000	(-30.30)		
		S6-L-B011-10.0-INT	10000	(-30.30)		
		S6-L-B011-3.0-ZJ-INT	3000	(-20.20)		
		S6-L-B011-5.0-ZJ-INT	5000	(-20.20)		
		S6-L-B011-10.0-ZJ-INT	10000	(-20.20)		

Motor Model		Cable Model	L Cable Length (mm)	Tolerance (T) (mm)	Illustration
MS1H3 motor rated 2.9 kW	Power cable for motor without brake	S6-L-M112-3.0-INT	3000	(-30.30)	
		S6-L-M112-5.0-INT	5000	(-30.30)	
		S6-L-M112-10.0-INT	10000	(-30.30)	
		S6-L-M112-3.0-ZJ-INT	3000	(-20.20)	
		S6-L-M112-5.0-ZJ-INT	5000	(-20.20)	
		S6-L-M112-10.0-ZJ-INT	10000	(-20.20)	
	Brake	S6-L-B112-3.0-INT	3000	(-30.30)	
		S6-L-B112-5.0-INT	5000	(-30.30)	
		S6-L-B112-10.0-INT	10000	(-30.30)	
		S6-L-B112-3.0-ZJ-INT	3000	(-20.20)	
		S6-L-B112-5.0-ZJ-INT	5000	(-20.20)	
		S6-L-B112-10.0-ZJ-INT	10000	(-20.20)	

Options

Motor Model		Cable Model	L Cable Length (mm)	Tolerance (T) (mm)	Illustration
MS1H3 motor rated 4.4 kW or above	Power cable for motor without brake	S6-L-M022-3.0-INT	3000	(-30.30)	<p>$L \pm T$</p>
		S6-L-M022-5.0-INT	5000	(-30.30)	
		S6-L-M022-10.0-INT	10000	(-30.30)	
		S6-L-M022-3.0-ZJ-INT	3000	(-20.20)	
		S6-L-M022-5.0-ZJ-INT	5000	(-20.20)	
		S6-L-M022-10.0-ZJ-INT	10000	(-20.20)	
	Brake	S6-L-B022-3.0-INT	3000	(-30.30)	<p>$L \pm T$</p>
		S6-L-B022-5.0-INT	5000	(-30.30)	
		S6-L-B022-10.0-INT	10000	(-30.30)	
		S6-L-B022-3.0-ZJ-INT	3000	(-20.20)	
		S6-L-B022-5.0-ZJ-INT	5000	(-20.20)	
		S6-L-B022-10.0-ZJ-INT	10000	(-20.20)	

Encoder cable

Motor Model		Cable Model	L Cable Length (mm)	Tolerance (T) (mm)	Illustration
MS1H1/MS1H4 motor	Multi-turn absolute encoder cable	S6-L-P124-3.0-INT	3000	(-30.30)	<p>$L \pm T$</p>
		S6-L-P124-5.0-INT	5000	(-30.50)	
		S6-L-P124-10.0-INT	10000	(-30.80)	
MS1H2/MS1H3 motor	Multi-turn absolute encoder cable	S6-L-P121-3.0-INT	3000	(-30.30)	<p>$L \pm T$</p>
		S6-L-P121-5.0-INT	5000	(-30.50)	
		S6-L-P121-10.0-INT	10000	(-30.80)	

Communication cables

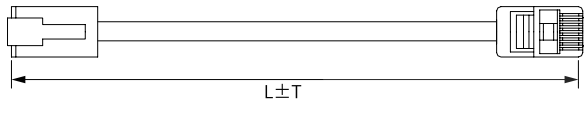
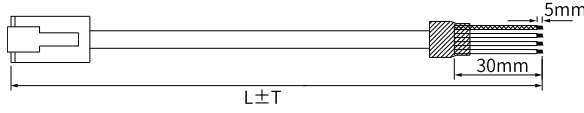
Cable Name	Cable Model	Cable Length (mm)	Tolerance (T) (mm)	Illustration
Servo drive network communication cable	S6-L-T04-0.3	300	(-10.10)	
Servo drive to host controller communication cable	S6-L-T02-2.0	2000	(-20.20)	

Connector Kit

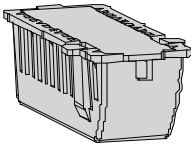
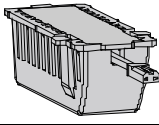
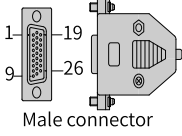
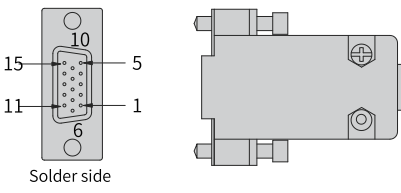
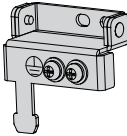
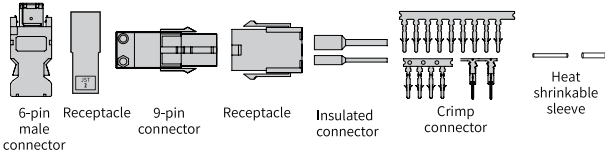
Name	Model	Outline Drawing
Battery box kit (without battery)	S6-C4A-NB	
Battery kit (with battery)	S6-C4A	
CN1 terminal (DB26)	S6-C74	 Male connector
CN7 terminal (DB15)	S6-C6	 Solder side
Shield bracket	S6-C25 (optional for SIZE A to SIZE C) S6-C27 (optional for SIZE D to SIZE E)	
MS1H1 lead-type (-S) motor connector	S6-C26	 6-pin male connector Receptacle 9-pin connector Receptacle Insulated connector Crimp connector Heat shrinkable sleeve

Name	Model	Outline Drawing
MS1H2/MS1H3 motor connector (1.8 kW and below)	S6-C29	<p>6-pin male connector, Receptacle, Crimp connector, circular connector, circular connector, Heat shrinkable sleeve, Insulation material, Insulated connector</p>
MS1H3 motor connector (2.9 kW and above)	S6-C39	<p>1394 male connector, Receptacle, Crimp connector, Circular connector, Circular connector, Heat shrinkable sleeve, Insulation material</p>

4.2.4 Cable Connectors

Power cable connector (motor side)

Table 4-1 Power cable connector (servo motor side)

Flange Size [1]	Illustration	Pin Layout		
		Pin No.	Signal Name	Color
40 60 80	<p>Black 6-pin connector</p>	1	PE	Yellow/Green
		2	W	Red
		3	V	Black
		4	U	White
		5	Brake (polarity insensitive)	Brown
		6		Blue

Table 4-2 Power cable connector (servo motor side)

Flange Size [1]	Illustration	Pin Layout		
		Pin No.	Signal Name	Color
100 130	<p>20-18 connector MIL-DTL-5015 series 3108E20-18S military-spec connector</p>	B	U	Blue
		I	V	Black
		F	W	Red
		G	PE	Yellow/Green
		C	Brake (polarity insensitive)	Red
		E		Black

Table 4-3 Power cable connector (servo motor side)

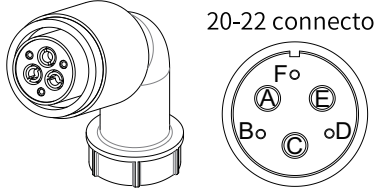
Flange Size [1]	Illustration	Pin Layout		
		Pin No.	Signal Name	Color
180	 <p>20-22 connector</p> <p>MIL-DTL-5015 series 3108E20-22S military-spec connector</p>	A	U	Blue
		C	V	Black
		E	W	Red
		F	PE	Yellow/Green
		B	Brake (polarity insensitive)	Red
		D		Black

Note

- [1] The flange size refers to the width of the mounting flange.
- Power cable colors are subject to the actual product. All cable colors mentioned in this guide refer to Inovance cable colors.

Encoder cable connector

Table 4-4 Encoder cable connector of motors

Motor Frame Size ^[1]	Illustration	Pin Layout			
		Pin No.	Signal Name	Color	Type
40	 <p>6-pin male (right side as the connecting side)</p>	1	+5V	Red	Twisted pair
		2	GND	Orange	
		5	PS+	Blue	Twisted pair
		6	PS-	Purple	
		Enclosure	PE	-	-
60 80	 <p>7-pin connector</p>	1	PS+	Blue	Twisted pair
2	PS-	Purple			
3	DC+	Brown	Twisted pair		
4	DC-	Black			
5	+5V	Red	Twisted pair		
6	GND	Orange			
7	PE	-	-		

Table 4–5 Encoder cable connector of motors

Motor Frame Size ^[1]	Illustration		Pin Layout			
			Pin No.	Signal Name	Color	Type
100 130 180		Servo drive side 6-pin male (right side as the connecting side)	1	+5V	Red	Twisted pair
			2	GND	Orange	
			5	PS+	Blue	Twisted pair
			6	PS-	Purple	
			Enclosure	PE	-	-
			Motor side 20-29 connector	A	PS+	Blue
	B	PS-		Purple		
	E	Battery (+)		Brown	-	
	F	Battery (-)		Black		
	G	+5V	Red	-		
H	GND	Orange				
J	Shield	-	-			

Note

[1]: The flange size refers to the width of the mounting flange (in mm).

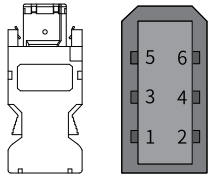
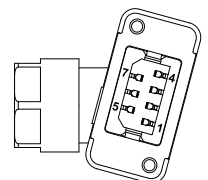
4.3 Peripheral Electrical Components

4.3.1 Fuse

To prevent accidents caused by short circuit, install a fuse on the input side of the drive.

Table 4–6 List of recommended fuses

Servo drive SV670-INT series			Fuse		
Size	Model	Rated input current (A)	Manufacturer	Rated current (A)	Model
Single-phase 200 V					
Size A	S1R6	2.3	Bussmann	5	FWP-5B
	S2R8	4.0		10	FWP-10B
Size C	S5R5	7.9		20	FWP-20B
	S7R6	9.6		20	FWP-20B
Size D	S012	12.8		20	FWP-20B
Three-phase 200 V					

Servo drive SV670-INT series			Fuse			
Size	Model	Rated input current (A)	Manufacturer	Rated current (A)	Model	
Size A	S1R6	1.1	Bussmann	5	FWP-5B	
	S2R8	2.3		5	FWP-5B	
Size C	S5R5	4.4		15	FWP-15B	
	S7R6	5.1		15	FWP-15B	
Size D	S012	8.0		20	FWP-20B	
Size E	S018	8.7		20	FWP-20B	
	S022	11.0		50	FWP-50C	
	S027	23.8		50	FWP-50C	
Three-phase 400 V						
Size C	T3R5	2.4		Bussmann	5	FWP-5B
	T5R4	3.6	10		FWP-10B	
Size D	T8R4	5.6	15		FWP-15B	
	T012	8.0	20		FWP-20B	
Size E	T017	12.0	35		FWP-35B	
	T021	16.0	35		FWP-35B	
	T026	21.0	40		FWP-40B	

4.3.2 Electromagnetic Contactor

Table 4-7 Recommended electromagnetic contactor models

Servo drive SV670-INT series			Contactor			
Size	Model	Rated input current (A)	Manufacturer	Current (A)	Model	
Single-phase 200 V						
Size A	S1R6	2.3	Schneider	9	LC1 D09	
	S2R8	4.0		9	LC1 D09	
Size C	S5R5	7.9		9	LC1 D09	
	S7R6	9.6		12	LC1 D12	
Size D	S012	12.8		18	LC1 D18	
Three-phase 200 V						
Size A	S1R6	1.1	Schneider	9	LC1 D09	
	S2R8	2.3				
Size C	S5R5	4.4				
	S7R6	5.1				
Size D	S012	8.0		9	LC1 D09	
Size E	S018	8.7		12	LC1 D12	
	S022	11.0				
	S027	23.8				
Three-phase 400 V						
Size C	T3R5	2.4		Schneider	9	LC1 D09
	T5R4	3.6	9		LC1 D09	
Size D	T8R4	5.6	9		LC1 D09	
	T012	8.0	9		LC1 D09	
Size E	T017	12.0	18		LC1 D18	
	T021	16.0	18		LC1 D18	
	T026	21.0	25		LC1 D25	

4.3.3 Circuit Breaker

Table 4–8 Recommended circuit breaker models

Servo drive SV670-INT series			Recommended circuit breaker			
Size	Model	Rated input current (A)	Manufacturer	Current (A)	Model	
Single-phase 200 V						
Size A	S1R6	2.3	Schneider	4	OSMC32N2D4	
	S2R8	4.0		6	OSMC32N2D6	
Size C	S5R5	7.9		16	OSMC32N2D16	
	S7R6	9.6		16	OSMC32N2D16	
Size D	S012	12.8		20	OSMC32N2D20	
Three-phase 200 V						
Size A	S1R6	1.1	Schneider	4	OSMC32N3D4	
	S2R8	2.3		6	OSMC32N3D6	
Size C	S5R5	4.4		16	OSMC32N3D16	
	S7R6	5.1		16	OSMC32N3D16	
Size D	S012	8.0		16	OSMC32N3D16	
Size E	S018	8.7		20	OSMC32N3D20	
	S022	11.0		25	OSMC32N3D25	
	S027	23.8		32	OSMC32N3D32	
Three-phase 400 V						
Size C	T3R5	2.4		Schneider	4	OSMC32N3D4
	T5R4	3.6	6		OSMC32N3D6	
Size D	T8R4	5.6	10		OSMC32N3D10	
	T012	8.0	16		OSMC32N3D16	
Size E	T017	12.0	20		OSMC32N3D20	
	T021	16.0	25		OSMC32N3D25	
	T026	21.0	32		OSMC32N3D32	

Note

- For UL-compliant products, see section "UL/cUL Certification" in the Hardware Guide for recommended fuse/circuit breaker models.
- This table only lists the recommended models. You can also use fuses/circuit breakers of the same specifications from other manufacturers that comply with UL North America certification.

If a residual current device (RCD) is needed, select the RCD according to the following requirements:

- Use a B-type RCD because the drive may generate DC leakage current in the protective conductor.
- For each drive, use an RCD whose tripping current is not lower than 100 mA to prevent RCD malfunction due to high-frequency leakage current generated by the drive.
- When multiple drives are connected in parallel and share one RCD, select an RCD whose tripping current is not lower than 300 mA.
- Use Chint or Schneider RCDs (recommended).

4.3.4 AC Input Reactor

EMC filter selection

An AC input reactor is optional and mainly used to reduce harmonics in the input current. Install an external reactor as needed in actual applications. The following table lists the recommended manufacturers and models of input reactors.

Table 4-9 AC input reactor model selection

Servo drive SV670-INT series			Applicable reactor	Inductance (mH)
Size	Model	Rated input current (A)		
Three-phase 200 V				
Size A	S1R6	1.1	MD-ACL-10-5-4T	5
	S2R8	2.3	MD-ACL-10-5-4T	5
Size C	S5R5	4.4	MD-ACL-10-5-4T	5
	S7R6	5.1	MD-ACL-10-5-4T	5
Size D	S012	8.0	MD-ACL-10-5-4T	5
Size E	S018	8.7	MD-ACL-15-3-4T	3
	S022	11.0	MD-ACL-15-3-4T	3
	S027	23.8	MD-ACL-40-1.45-4T	1.45
Three-phase 400 V				
Size C	T3R5	2.4	MD-ACL-10-5-4T	5
	T5R4	3.6	MD-ACL-10-5-4T	5
Size D	T8R4	5.6	MD-ACL-10-5-4T	5
	T012	8.0	MD-ACL-10-5-4T	5
Size E	T017	12.0	MD-ACL-15-3-4T	3
	T021	16.0	MD-ACL-40-1.45-4T	1.45
	T026	21.0	MD-ACL-40-1.45-4T	1.45

Dimensions

- Inovance input reactors

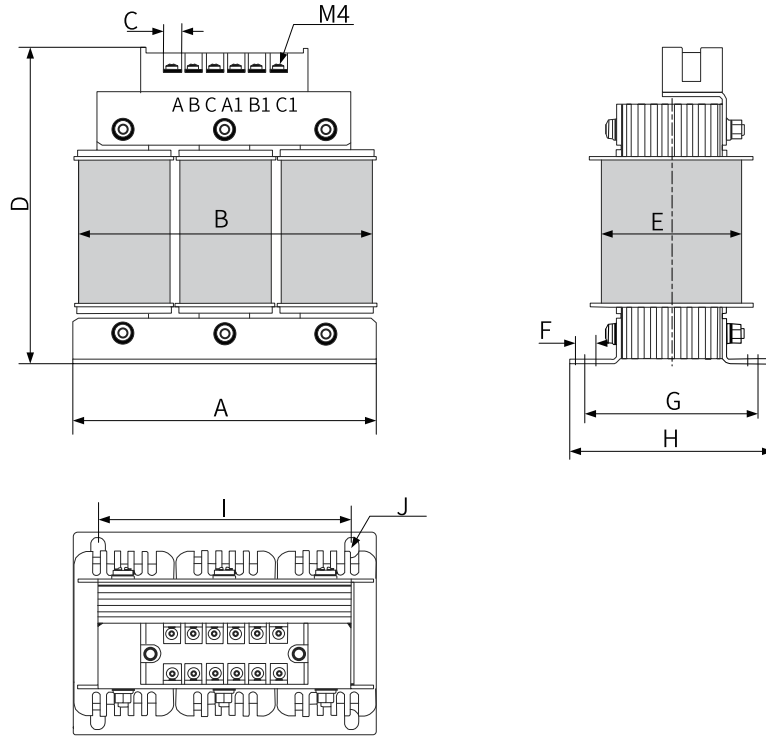

Figure 4-1 Dimensions of 10 A to 15 A AC input reactors

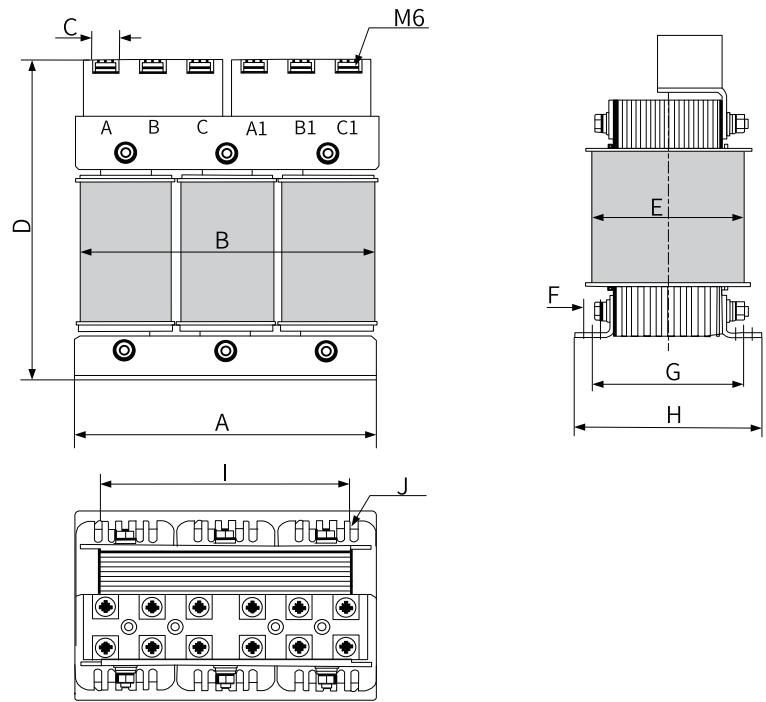

Figure 4-2 Dimensions of 40 A (1.45 mH) AC input reactors

Table 4-10 Dimensions of Inovance AC input reactors (unit: mm)

Model	A	B	C	D	E	F	G	H	I	J
MD-ACL-10-5-4T	150±2	155	8	160	80	10	85±2	100±2	125±1	Φ7x10
MD-ACL-15-3-4T	150±2	155	8	160	80	10	85±2	100±2	125±1	Φ7x10
MD-ACL-40-1.45-4T	180±2	185	16	200	105	10	95±2	117±2	150±1	Φ7x10

4.3.5 EMC Filter

EMC filter selection

To comply with EN IEC 61800-3 requirements in terms of radiated and conducted emission, install an EMC filter listed in the following table. You can select FN 2090 and FN 3287 series EMC filters manufactured by Schaffner. Select the EMC filter according to the rated input current of the drive, as shown in the following table.

Table 4–11 Standard EMC filter model and appearance



Filter Model		Appearance
Schaffner	FN 2090 series	
	FN 3287 series	

Table 4–12 Filter model selection (Schaffner)

Servo drive SV670-INT series			Applicable Filter
Size	Model	Rated input current (A)	
Single-phase 200 V			
Size A	S1R6	2.3	FN 2090-3-06
	S2R8	4.0	FN 2090-4-06
Size C	S5R5	7.9	FN 2090-8-06
	S7R6	9.6	FN 2090-10-06
Size D	S012	12.8	FN 2090-16-06
Three-phase 200 V			
Size A	S1R6	1.1	FN 3287-10-44-C28-R65
	S2R8	2.3	FN 3287-10-44-C28-R65
Size C	S5R5	4.4	FN 3287-10-44-C28-R65
	S7R6	5.1	FN 3287-10-44-C28-R65
Size D	S012	8.0	FN 3287-10-44-C28-R65
Size E	S018	8.7	FN 3287-10-44-C28-R65
	S022	11.0	FN 3287-16-44-C33-R65
	S027	23.8	FN 3287-25-33-C33-R65
Three-phase 400 V			
Size C	T3R5	2.4	FN 3287-10-44-C28-R65
	T5R4	3.6	FN 3287-10-44-C28-R65

Servo drive SV670-INT series			Applicable Filter
Size	Model	Rated input current (A)	
Size D	T8R4	5.6	FN 3287-10-44-C28-R65
	T012	8.0	FN 3287-10-44-C28-R65
Size E	T017	12.0	FN 3287-16-44-C33-R65
	T021	16.0	FN 3287-16-44-C33-R65
	T026	21.0	FN 3287-25-33-C33-R65

Dimensions

- Dimensions of Schaffner FN 2090 series filters

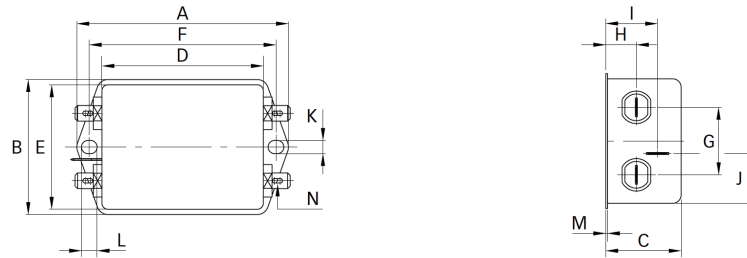

Figure 4-3 Dimensions of FN 2090 series filters (unit: mm)

Table 4-13 Dimensions of FN 2090 series filters (unit: mm)

Rated current (A)	A	B	C	D	E	F	G	H	I	J	K	L	M	N
3	85	54	30.3	64.8	49.8	75	27	12.3	20.8	19.9	5.3	6.3	0.7	6.3x0.8
4														
6														
8	113.5±1	57.5±1	45.4±1	94±1	56	103	25	12.4	32.4	15.5	4.4	6	1	6.3x0.8

- Dimensions of Schaffner FN 3287 series filters

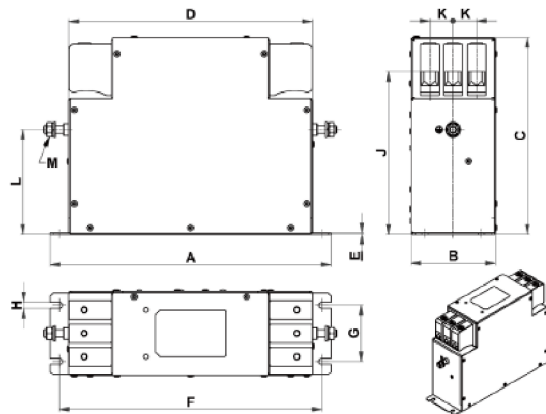

Figure 4-4 Dimension drawing of FN 3287 series filters (unit: mm)

Table 4–14 Dimensions of FN 3287 series filters (unit: mm)

Rated current (A)	A	B	C	D	E	F	G	H	J±2	K	L±1	M
10	180	40	112	153	0.8	170	20	4.5	94	11	68	M5
16	200	45	112	170	0.8	185	25	5.4	102	11	76	M5
25	205	45	132	173	0.8	190	25	5.4	113	13	83	M5

4.3.6 Magnetic Ring and Magnetic Buckle

The magnetic ring is intended to be installed on the input or output side of the drive. Install the magnetic ring as close to the drive as possible. Installing the magnetic ring on the input side can suppress the noise in the input power supply system of the drive. When it is installed on the output side, it can reduce the interference generated by the drive to external devices and can reduce the bearing current.

In applications with leakage current and signal cable interference, install a magnetic ring or a ferrite clamp.

EMC filter selection

- Amorphous magnetic ring: featuring high permeability when the frequency is within 1 MHz and excellent anti-interference performance, but not as low-cost as the ferrite clamp. See for details. “[Dimensions](#)” on page 86.
- Ferrite clamp: featuring a good interference suppression performance within a frequency band above 1MHz, applicable to low-power servo drives and signal cables, low-cost and easy to install

Magnetic Ring and Ferrite Clamp		Appearance
Magnetic ring	DY644020H	
	DY805020H	
Ferrite clamp	DYR-130-B	

Dimensions

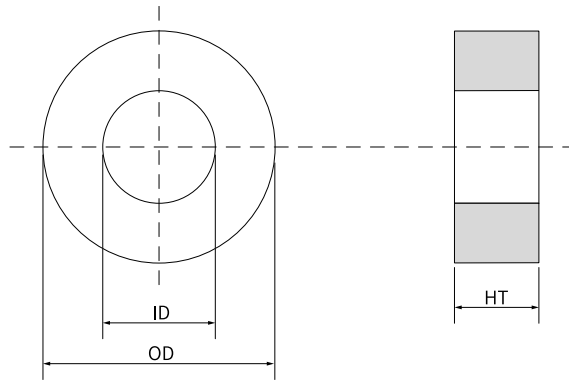

Figure 4-5 Dimensions of the magnetic ring

Table 4-15 Dimensions of the magnetic ring

Model	Size (OD×ID×HT) (mm)
DY644020H	64 × 40 × 20
DY805020H	80 × 50 × 20

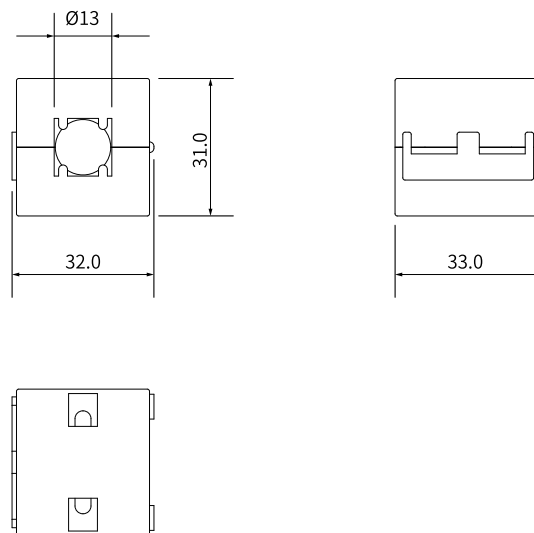

Figure 4-6 Dimensions of the ferrite clamp

Table 4-16 Dimensions of the ferrite clamp

Model	Size (Length × OD × ID) (mm)
DYR-130-B	32.0 × 31 × 13

4.4 Shield bracket

To reduce electromagnetic interference, an EMC bracket and clamp are used with the drive cables.

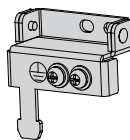

Figure 4-7 Shield bracket

4.5 Absolute Encoder Batteries

EMC filter selection

Select an appropriate battery according to the following table.

Table 4-17 Description of the absolute encoder battery

Specification	Item	Rating			Condition
		Min.	Typical Value	Max.	
Output: 3.6 V, 2500 mAh	External battery voltage (V)	3.2	3.6	5	In standby state ^[1]
	Circuit fault voltage (V)	-	2.6	-	In standby state
	Battery alarm voltage (V)	2.85	3	3.15	-
	Current consumed by the circuit (uA)	-	2	-	In normal operation ^[2]
		-	10	-	In standby state, shaft at standstill
		-	80	-	In standby state, shaft rotating
	Ambient temperature (°C)	0	-	40	Same as the motor.
Storage temperature (°C)	-20	-	60		

The preceding values are obtained under an ambient temperature of 20°C.

Note

- [1]: The "standby state" means the encoder counts the multi-turn data by using the power from the external battery when the servo drive power supply is not switched on. In this case, data transceiving stops.
- [2]: During normal operation, the absolute encoder supports one-turn or multi-turn data counting and transceiving. Power on the servo drive after connecting the absolute encoder properly. The encoder starts data transceiving after a short delay of about 5s upon power-on. The motor speed must be lower than or equal to 10 rpm during transition from the standby state to the normal operation state (upon power-on). Otherwise, Er.740 (Encoder fault) may occur. In this case, you need to power off and on the servo drive again.

5 Certification Requirements

CE Certification

Directive	Standard	
EMC Directive 2014/30/EU	Servo drive	EN 61800-3
	Servo motor	EN 61800-6-2
		EN 61800-6-4
		EN 55011
Low Voltage Directive 2014/35/EU	Servo drive	EN 61800-5-1
	Servo motor	EN 60034-1 EN 60034-5
RoHS Directive 2011/65/EU	Servo drive	EN 50581
	Servo motor	

UL/cUL certification

Certification	Standard	
UL/cUL certification	Servo drive	UL61800-5-1 C22.2 No.274-17
	Servo motor	UL 1004-1 UL 1004-6 CSA C22.2 No. 100-14

Note

The drive complies with the latest version of directives and standards for CE and UL/cUL certifications.

KC certification

Certification	Standard	
KC certification	Servo drive	KN 61800-3 (Ver 2014.06) (IEC 61800-3 Ver 2012.03)

Others

The SV670-INT series servo drives comply with EAC and UKCA certifications.

6 Service and Support

Downloads

More product manuals, leaflets, brochures, certificates, 2D/3D drawings and other information can be downloaded in the following ways:

Do keyword search under “Service and Support-After-sales Service” at <https://www.inovance.com>“”.

Contact us

We are honored to have you as our client. You can submit basic information to us in the following way, so that we can reach you as soon as possible. We are committed to your privacy. We will never share your information with any third party.

Go to our official website (<https://www.inovance.com>), select “Service and Support-Contact Us”, and submit your information.

After-sales service

If you have product quality problems and need after-sales service, or you need to purchase spare parts, you can get the after-sales service person in your region through the following way.

Go to our official website (<https://www.inovance.com>), select “Service and Support-After-sales Service”, and submit the product category and your region.

Repair service

If a product is in trouble and needs to be repaired, you can check the maintenance instructions, submit the service request and check the service record in the following way.

Go to our official website (<https://www.inovance.com>), select “Service and Support-Repair”, and submit the repair request.

Authentication

You can authenticate Inovance products in the following way:

Go to our official website (<https://www.inovance.com>), select “Service and Support-Authentication”, and enter the 16-digit serial number.

FAQ

You can go through frequently asked questions about Inovance products in the following way:

Go to our official website (<https://www.inovance.com>) and select “Service and Support-FAQ”.

Feedback

You can submit your feedback in the following way:

Go to our official website (<https://www.inovance.com>), select “Service and Support-Feedback”, and submit your feedback.

Forum

The forum provides high-quality courses for beginners and advanced learners. You are free to learn and share there. To get access to the forum:

Go to our official website (<https://www.inovance.com>) and select “Service and Support-Forum”.



Copyright © Shenzhen Inovance Technology Co., Ltd.

PS00009734A00

Shenzhen Inovance Technology Co., Ltd.

www.inovance.com

Add.: Inovance Headquarters Tower, High-tech Industrial Park,
Guanlan Street, Longhua New District, Shenzhen

Tel: (0755) 2979 9595

Fax: (0755) 2961 9897

Suzhou Inovance Technology Co., Ltd.

www.inovance.com

Add.: No. 16 Youxiang Road, Yuexi Town,
Wuzhong District, Suzhou 215104, P.R. China

Tel: (0512) 6637 6666

Fax: (0512) 6285 6720